

Performance, robustness and reliability: **PMXT ENDURANCE**

Caprari has launched the new range of high pressure multistage surface horizontal pump series **PMXT ENDURANCE** completely made of precision-cast stainless steel.

Very thick components, the choice of high performing materials, the innovative technical solutions and the smooth surface of hydraulic profiles make the **PMXT ENDURANCE** pumps unique on the market for their performance, robustness and reliability.

The pumps are:

- Able to reach performance values up to 100 bar pressure with top-level efficiency ratings
- Made of AISI 316 stainless steel precision-castings suitable for harsh operating conditions

Also available are full duplex and full super duplex versions, which are suitable for extreme industrial applications (i.e. reverse osmosis, seawater fire prevention, seawater injection, etc).

The balanced mechanical seals have been specifically selected for industrial applications.

The Caprari axial thrust compensation system is present on the whole range, minimising the loads that persist on the bearings of the machine, giving the product a long life.

The wear rings are replaceable and made in duplex with anti-seizing properties and self-lubricated. At the same time, this solution makes it possible to minimise the gap between the impeller and the wear ring, improving hydraulic efficiency and avoiding seizure problems.

Optional PT100 probes are useful for monitoring bearing temperatures. Together with the vibration probes, which are also optional, it is easy to monitor the wear level of the bearings, thus preventing costly downtime.

Caprari surface groups made with high-pressure multistage pumps are a benchmark for the market. The product's wide range makes it possible to always find the best solution for the customer's duty point at the highest efficiency level.

With the **ENDURANCE** series in stainless steel and duplex, Caprari satisfies the most demanding industrial market applications.

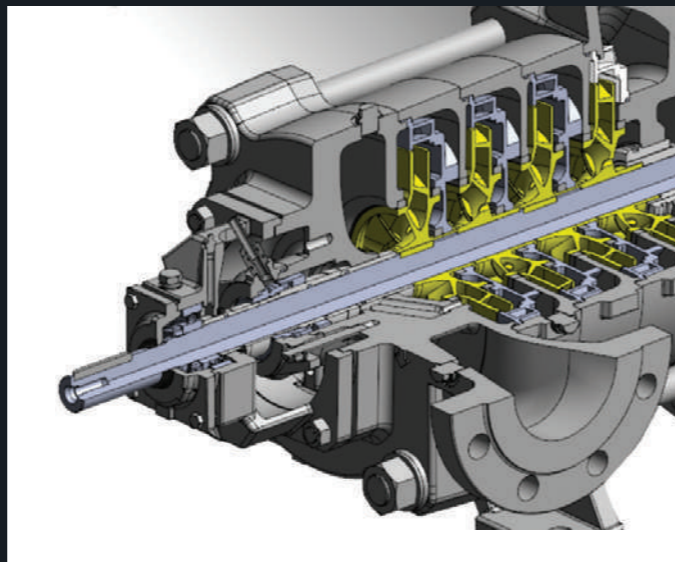

Caprari Group is one of the most important international manufacturers of centrifugal pumps and electric pumps, providing advanced solutions for managing the integrated water cycle.

YOUR RELIABLE PARTNER
IN INDUSTRIAL APPLICATIONS

EXPERIENCE SINCE 1945

Designing the future with highly appreciated and advanced solutions for **Industrial Applications**. Pumps and electric pumps able to raise primary process water and waste water.



ENERGY | METAL INDUSTRY | PAPER INDUSTRY | FOOD & BEVERAGE

www.caprari.com

