

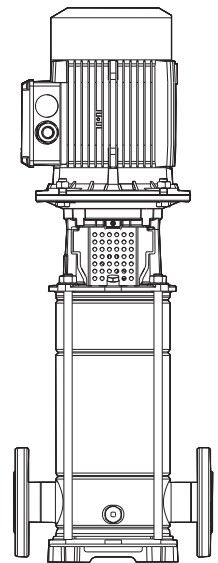

MULTISTAGE VERTICAL ELECTRIC PUMPS
ELECTROBOMBAS MULTIETAPAS VERTICALES
ELETTROPOMPE MULTISTADIO VERTICALI

CVD

Poles
Pole 2 60 Hz
Poli



caprari

pumping power

ISO 9001
ISO 14001
ISO 45001
BUREAU VERITAS
Certification



PUMP CODING - EJEMPLIFICACIÓN DE LAS SIGLAS - ESEMPLIFICAZIONE SIGLA

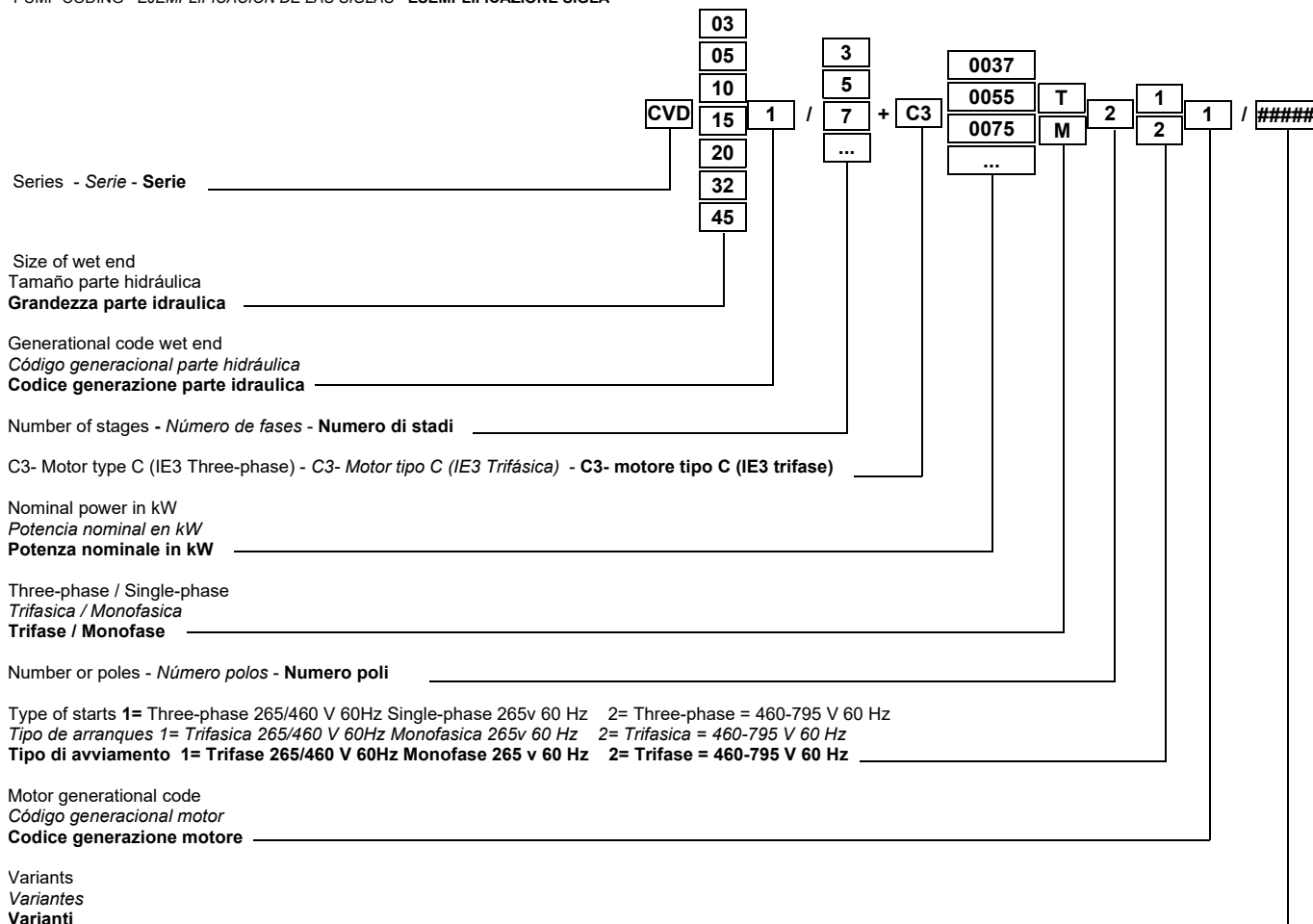

SPECIFICATIONS - CARACTERÍSTICAS - CARATTERISTICHE

• Inlet/outlet ports	In line	• Bocas entrada/salida	De linea	• Bocche ingresso/uscita	In linea
• Seal	Mechanical	• Cierre	Mecanica	• Tenuta	Meccanica
• Max. temperature of pump liquid	+110°C	• Temperatura máx. líquido elevado	+110 [grados C]	• Temperatura max. líquido sollevato	+110°C
• Frequency	Multi-frequency	• Frecuencia	Multifrecuencia	• Frecuencia	Multifrecuencia
• Efficiency class	IE3	• Clase de eficiencia	IE3	• Classe di efficienza	IE3
• IP	55	• IP	55	• IP	55
• Poles	2	• Polos	2	• Poli	2
• VSD (inverter)	Compatible	• VSD (inverter)	Compatible	• VSD (inverter)	Compatibile

TOLERANCES - TOLERANCIAS - TOLLERANZE

Given specifications relate to cold water (15 °C) at a pressure of 1 bar (atmospheric) and are guaranteed as for all series pumps according to UNI/ISO 9906 Grade 3B. The data given in the catalogue refer to liquids with a volume mass of 1 kg/dm³ and kinematic viscosity of not more than 1 mm²/s.

Las características de funcionamiento han sido obtenidas en agua fría (15 °C) a presión atmosférica (1 bar) y vienen garantizadas, tratándose de bombas construidas en serie, según las normas UNI/ISO 9906 Nivel 3B. Los datos de catálogo se refieren a líquidos con densidad de 1 [kg/dm³] y con viscosidad cinemática no superior a 1 [mm²/s].

Le caratteristiche di funzionamento sono state rilevate con acqua fredda (15 °C) alla pressione atmosferica (1 bar) e vengono garantite, trattandosi di pompe costruite in serie, secondo le norme UNI/ISO 9906 grado 3B. I dati di catalogo si riferiscono a liquidi con densità di 1kg/dm³ e con viscosità cinemática non superiore a 1mm²/s.

031
 051
 101
 151
 201

321
 451

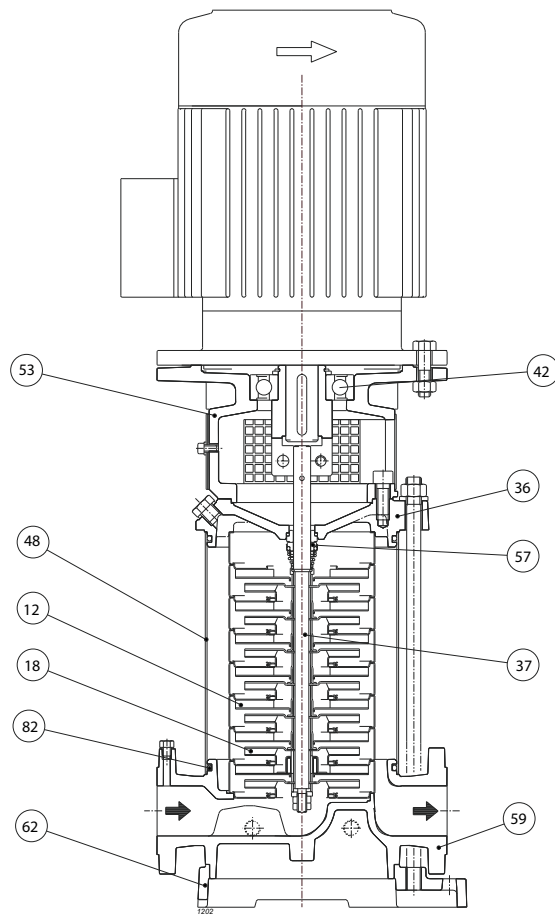
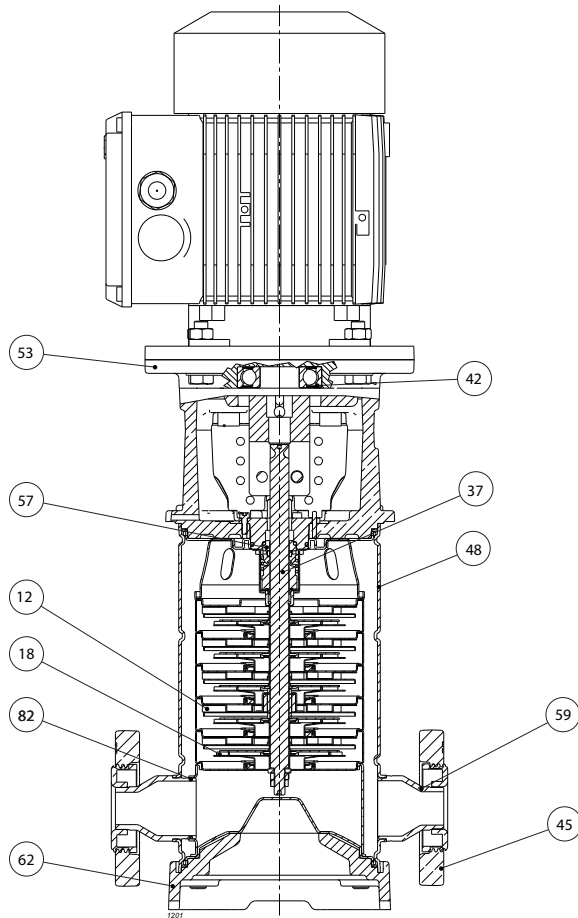

Pos.	Parts	Materials	Numero	Materials	Nomenclatura	Materiale
12	Diffuser	Stainless steel	<i>Difusor</i>	<i>Acero inox</i>	Diffusore	Acciaio inox
18	Impeller	Stainless steel	<i>Rodete</i>	<i>Acero inox</i>	Girante	Acciaio inox
36	Pump head (321-451)	Cast iron	<i>Cabezal de la bomba (321-451)</i>	<i>Hierro fundido</i>	Testata pompa (321-451)	Ghisa grigia
37	Shaft	Stainless steel	<i>Eje</i>	<i>Acero inox</i>	Albero	Acciaio inox
42	Bearing	Tungsten carbide/ceramic	<i>Cojinete</i>	<i>Carburo de tungsteno/ cerámica</i>	Cuscinetto	Carburo di tungsteno/ ceramica
45	Inlet/Outlet Flanges (031-051-101-151-201)	Cast iron	<i>Bridas entrada/salida (031-051-101-151-201)</i>	<i>Hierro fundido</i>	Flange ingresso/uscita (031-051-101-151-201)	Ghisa grigia
48	Stage casing	Stainless steel	<i>Carcasa exterior</i>	<i>Acero inox</i>	Camicia esterna	Acciaio inox
53	Lantern bracket	Cast iron	<i>Soporte de union</i>	<i>Hierro fundido</i>	Supporto di collegamento	Ghisa grigia
57	Mechanical seal (031-051-101-151-201)	Silicon carbide/Carbon/ Rubber	<i>Cierre mecánico (031-051-101-151-201)</i>	<i>Carburo de silicio/Carbon/ Goma</i>	Tenuta meccanica (031-051-101-151-201)	Carburo di silicio/Carbone/ Gomma
57	Mechanical seal (321-451)	Tungsten carbide/Carbon/ Rubber	<i>Cierre mecánico (321-451)</i>	<i>Carburo de tungsteno/ Carbon/Goma</i>	Tenuta meccanica (321-451)	Carburo di tungsteno/ Carbone/Gomma
59	Pump casing (031-051-101-151-201)	Stainless steel	<i>Cuerpo bomba (031-051-101-151-201)</i>	<i>Acero inox</i>	Corpo pompa (031-051-101-151-201)	Acciaio inox
59	Pump casing (321-451)	Cast iron	<i>Cuerpo bomba (321-451)</i>	<i>Hierro fundido</i>	Corpo pompa (321-451)	Ghisa grigia
62	Base plate	Cast iron	<i>Placa base</i>	<i>Hierro fundido</i>	Piastra base	Ghisa grigia
82	Seal ring	Rubber	<i>Anillo de sellado</i>	<i>Goma</i>	Anello di tenuta	Gomma

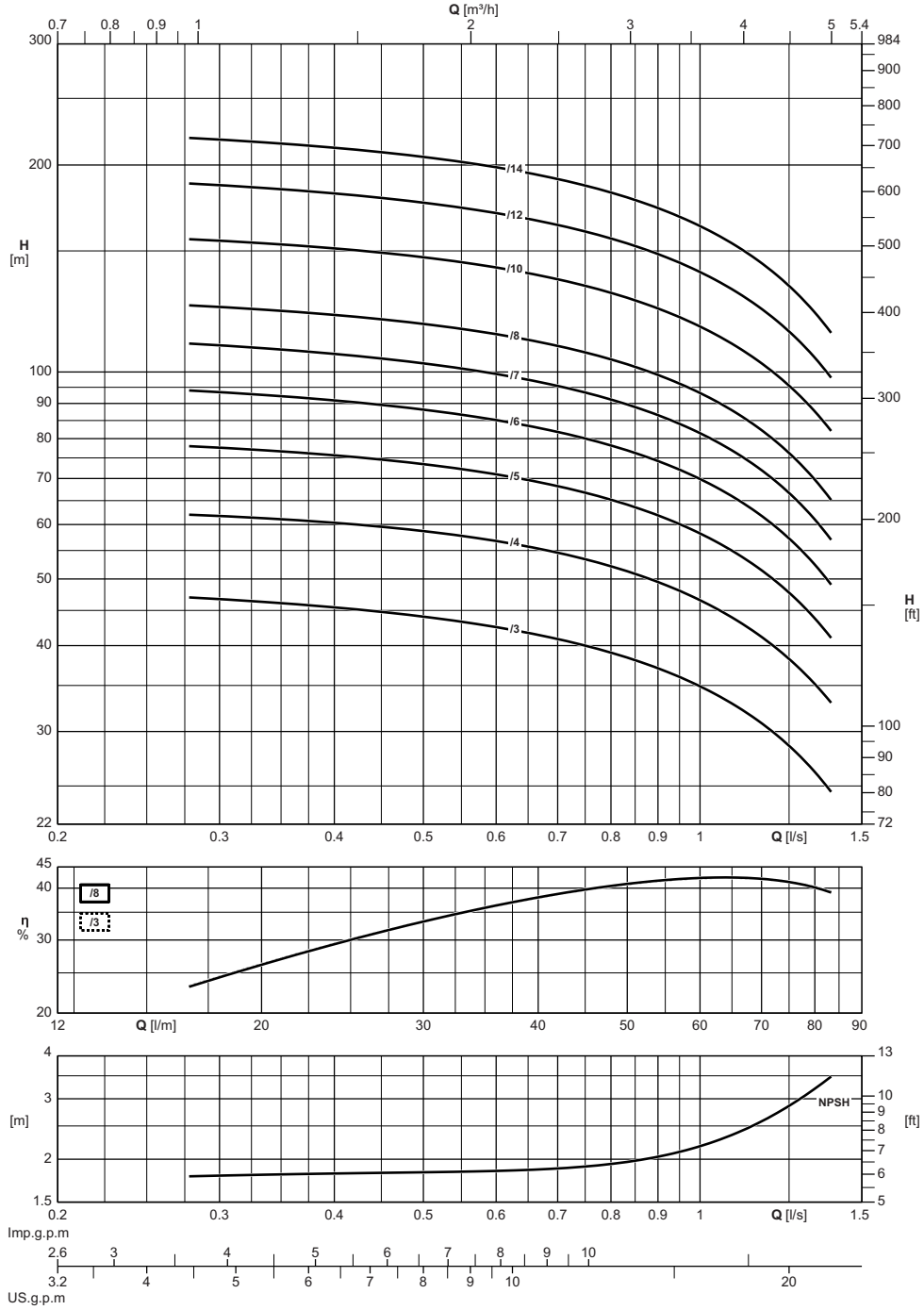

Electric pump type <i>Electrobomba tipo</i> Elettropompa tipo		Motor power <i>Potencia motor</i> Potenza motore		Capacity / Caudal / Portata													
				[l/s]	0,3	0,4	0,5	0,6	0,7	0,8	0,9	1	1,2	1,4			
Single-phase <i>Monofasica</i> Monofase	Three-phase <i>Trifasica</i> Trifase	[kW]	[CV]	[m³/h]	1,1	1,4	1,8	2,2	2,5	2,9	3,2	3,6	4,3	5			
				[l/min]	18	24	30	36	42	48	54	60	72	84			
				Total manometric head <i>Altura manometrica total</i> Prevalenza manometrica totale													
				[m]	46,5	45,5	44	42,5	41	39	37	35	30	24,5			
	CVD031/3+C30110T211-Z	1,1	1,5	[m]	62	60	59	57	55	52	49,5	46,5	40	33,5			
	CVD031/4+C30110T211-Z	1,1	1,5	[m]	78	76	73	71	68	65	62	58	50	41,5			
	CVD031/5+C30150T211-Z	1,5	2	[m]	94	91	88	85	82	78	74	70	60	49,5			
	CVD031/6+C30220T211-Z	2,2	3	[m]	109	106	103	99	95	91	87	82	70	58			
	CVD031/7+C30220T211-Z	2,2	3	[m]	124	121	118	114	109	104	99	93	80	66			
	CVD031/8+C30300T211-Z	3	4	[m]	155	151	147	142	136	130	124	116	100	83			
	CVD031/10+C30300T211-Z	3	4	[m]	187	182	176	170	164	156	148	140	120	99			
	CVD031/12+C30400T221-Z	4	5,5	[m]	218	212	206	199	191	182	173	163	140	115			
	CVD031/14+C30400T221-Z	4	5,5	[m]	1,8	1,8	1,8	1,8	1,9	1,9	2	2,2	2,7	-			
NPSH				[m]	1,8	1,8	1,8	1,8	1,9	1,9	2	2,2	2,7	-			

M.E.I. ≥ 0.40

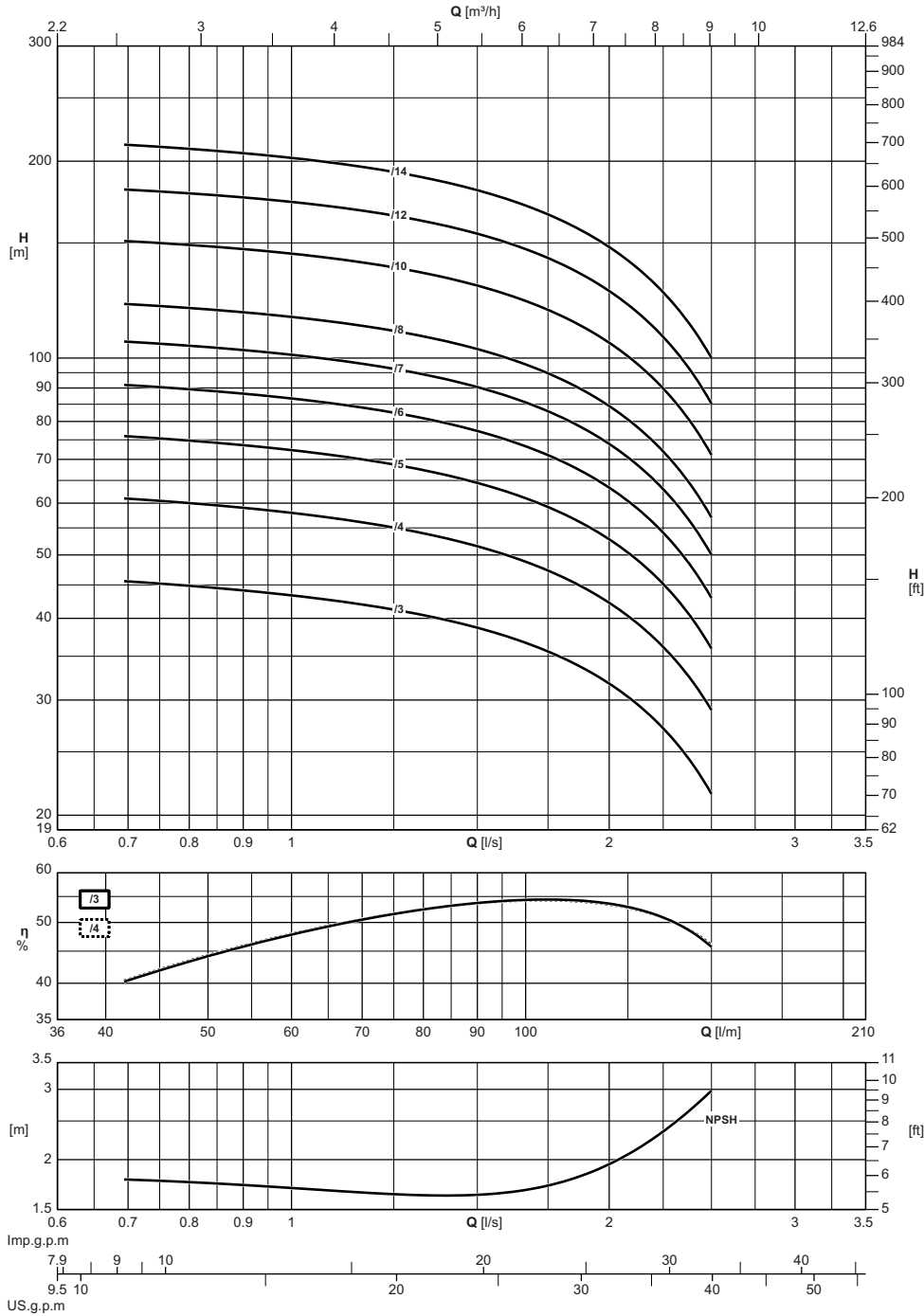

Electric pump type Electrobomba tipo Elettropompa tipo		Motor power Potencia motor Potenza motore		Capacity / Caudal / Portata													
				[l/s]	0,7	0,8	0,9	1	1,2	1,4	1,6	1,8	2	2,2	2,4		
Single-phase Monofase	Three-phase Trifase	[kW]	[CV]	[m³/h]	2,5	2,9	3,2	3,6	4,3	5	5,8	6,5	7,2	7,9	8,6		
				[l/min]	42	48	54	60	72	84	96	108	120	132	144		
	CVD051/3+C30150T211-Z	1,5	2	[m]	45,5	45	44	43,5	41,5	40	37,5	35	32	28	24		
	CVD051/4+C30220T211-Z	2,2	3	[m]	61	60	59	58	56	53	50	46,5	42	37,5	32		
	CVD051/5+C30220T211-Z	2,2	3	[m]	76	75	74	72	70	66	62	58	53	47	40		
	CVD051/6+C30300T211-Z	3	4	[m]	91	90	88	87	83	80	75	70	63	56	47,5		
	CVD051/7+C30300T211-Z	3	4	[m]	106	104	103	101	97	93	88	81	74	65	56		
	CVD051/8+C30400T221-Z	4	5,5	[m]	121	119	118	116	111	106	100	93	84	75	63		
	CVD051/10+C30400T221-Z	4	5,5	[m]	151	149	147	144	139	133	125	116	106	93	79		
	CVD051/12+C30550T221-Z	5,5	7,5	[m]	181	179	176	173	167	159	150	139	127	112	95		
	CVD051/14+C30550T221-Z	5,5	7,5	[m]	212	209	206	202	195	186	175	163	148	131	111		
NPSH				[m]	1,8	1,8	1,7	1,7	1,6	1,6	1,7	1,8	2	2,3	2,7		

M.E.I. ≥ 0.40

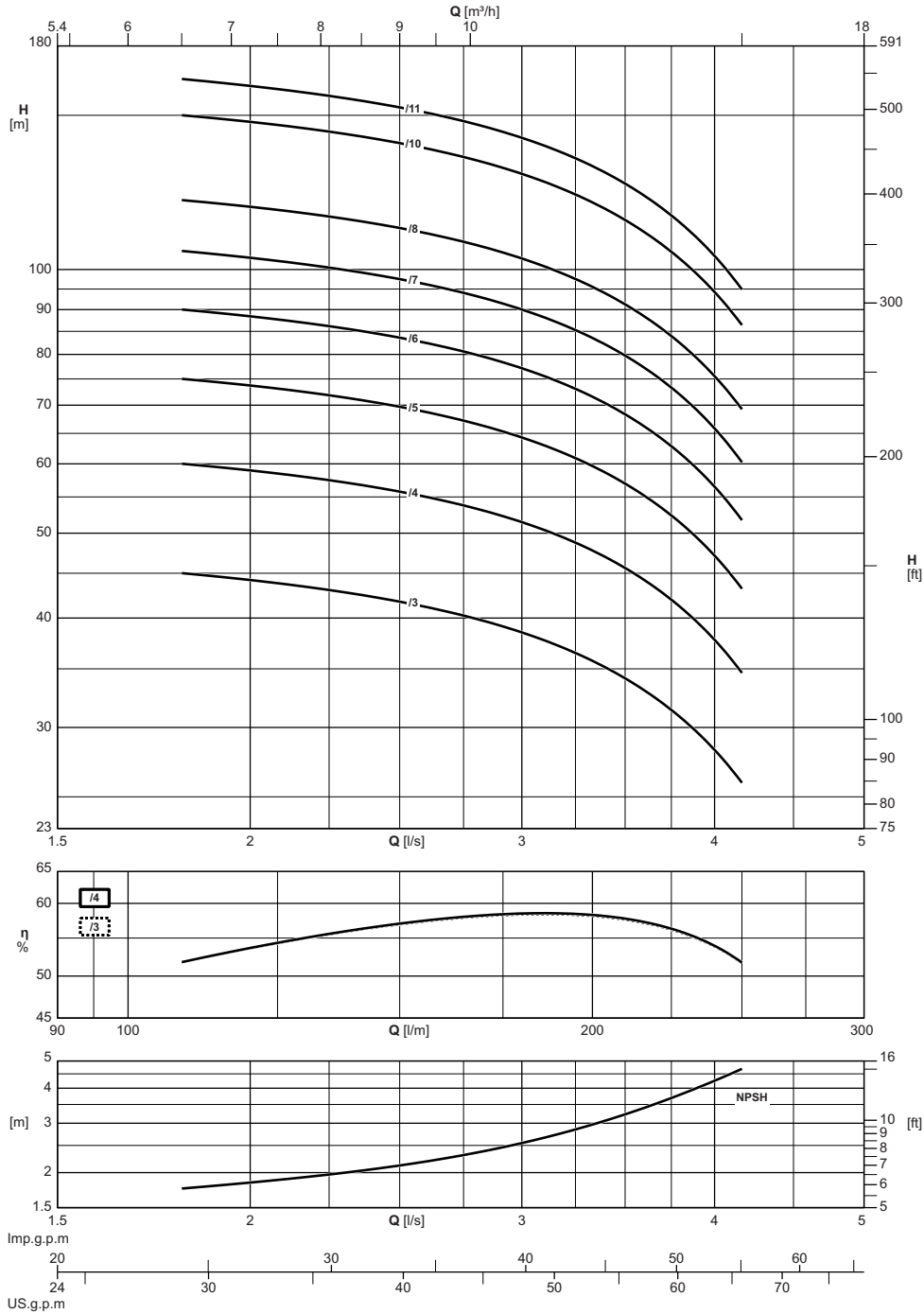

Electric pump type <i>Electrobomba tipo</i> Elettropompa tipo		Motor power <i>Potencia motor</i> Potenza motore		Capacity <i>Caudal</i> Portata														
				[l/s]	1,8	2	2,2	2,4	2,6	2,8	3	3,2	3,4	3,6	3,8	4		
				[m³/h]	6,5	7,2	7,9	8,6	9,4	10,1	10,8	11,5	12,2	13	13,7	14,4		
[l/min]	108	120	132	144	156	168	180	192	204	216	228	240						
Single-phase <i>Monofase</i> Monofase	Three-phase <i>Trifase</i> Trifase	[kW]	[CV]	Total manometric head <i>Altura manometrica total</i> Prevalenza manometrica totale														
	CVD101/3+C30220T211-Z	2,2	3	[m]	45	44	43,5	42,5	41	40	38,5	37	35	33	31	28,5		
	CVD101/4+C30300T211-Z	3	4	[m]	60	59	58	57	55	53	52	49,5	47	44	41	38		
	CVD101/5+C30400T221-Z	4	5,5	[m]	75	74	72	71	69	67	64	62	59	55	51	47		
	CVD101/6+C30400T221-Z	4	5,5	[m]	90	88	87	85	82	80	77	74	70	66	62	57		
	CVD101/7+C30550T221-Z	5,5	7,5	[m]	105	103	101	99	96	93	90	86	82	77	72	66		
	CVD101/8+C30550T221-Z	5,5	7,5	[m]	120	118	116	113	110	107	103	99	94	88	82	76		
	CVD101/10+C30750T221-Z	7,5	10	[m]	150	147	145	141	138	133	129	123	117	110	103	94		
	CVD101/11+C30750T221-Z	7,5	10	[m]	165	162	159	155	151	147	141	136	129	122	113	104		
NPSH				[m]	1,7	1,8	1,9	2,1	2,2	2,4	2,6	2,8	3,1	3,4	3,8	4,3		
M.E.I. ≥ 0.40																		

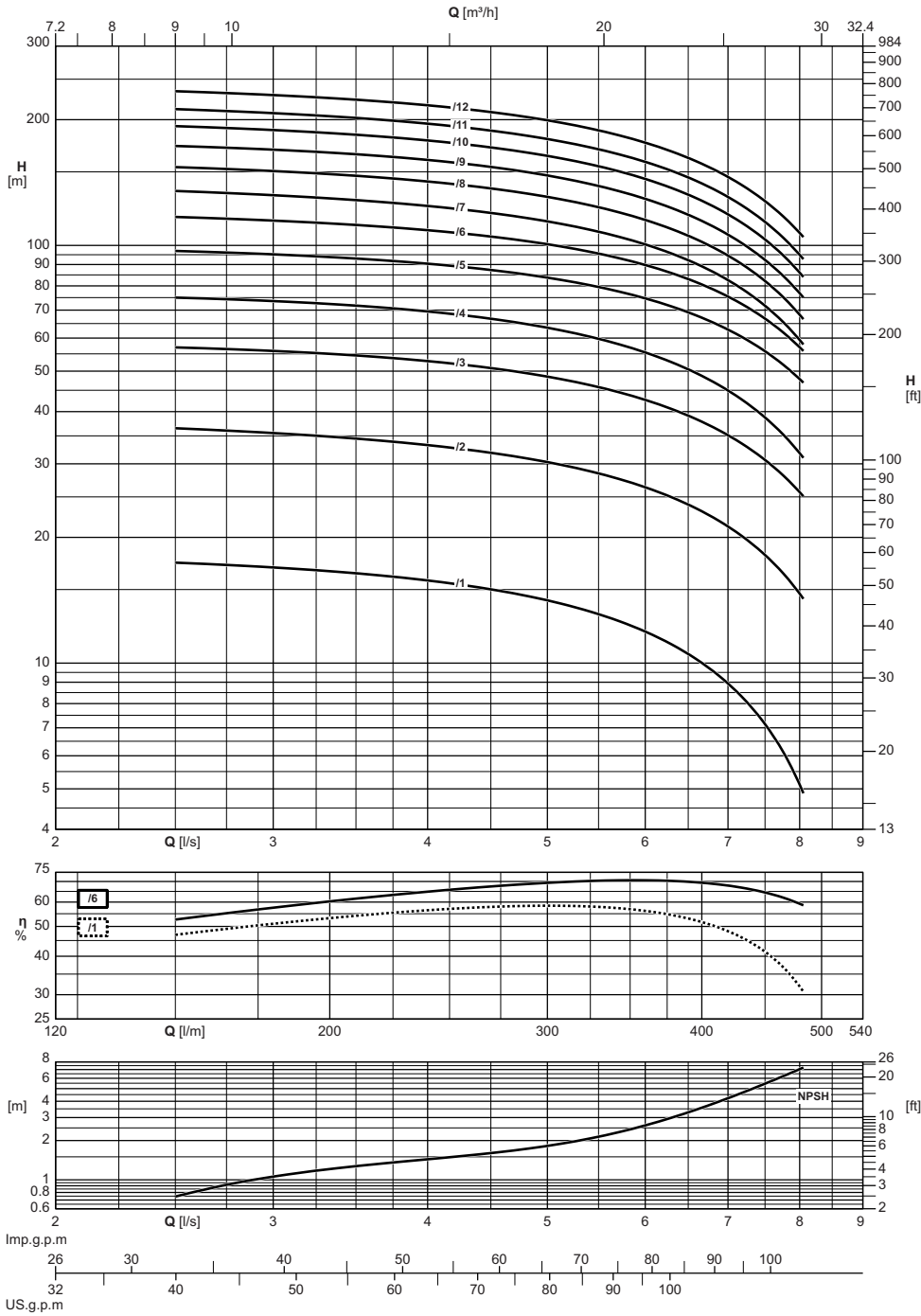

Electric pump type <i>Electrobomba tipo</i> Elettropompa tipo		Motor power <i>Potencia motor</i> Potenza motore		Capacity / Caudal / Portata													
				[l/s]	2,8	3	3,2	3,4	3,6	3,8	4	5	6	7	8		
				[m ³ /h]	10,1	10,8	11,5	12,2	13	13,7	14,4	18	21,5	25	29		
				[l/min]	168	180	192	204	216	228	240	300	360	420	480		
Single-phase <i>Monofasica</i> Monofase	Three-phase <i>Trifasica</i> Trifase	[kW]	[CV]	Total manometric head <i>Altura manometrica total</i> Prevalenza manometrica totale													
				[m]	17	17	16,5	16,5	16,5	16	16	14	12	8,9	5,1		
	CVD151/1+C30150T211-Z	1,5	2	[m]	17	17	16,5	16,5	16,5	16	16	14	12	8,9	5,1		
	CVD151/2+C30300T211-Z	3	4	[m]	36	35,5	35	34,5	34	34	33,5	30,5	26,5	21	14,5		
	CVD151/3+C30400T221-Z	4	5,5	[m]	56	56	55	55	54	54	53	48,5	42,5	35	25,5		
	CVD151/4+C30550T221-Z	5,5	7,5	[m]	74	74	73	72	71	70	70	64	55	45	32		
	CVD151/5+C30750T221-Z	7,5	10	[m]	96	95	94	94	93	92	90	84	75	63	48		
	CVD151/6+C30750T221-Z	7,5	10	[m]	116	115	114	113	111	110	109	101	90	75	57		
	CVD151/7+C30920T221-Z	9,2	12,5	[m]	133	132	131	129	128	126	124	114	101	83	59		
	CVD151/8+C31100T221-Z	11	15	[m]	152	151	149	148	146	144	142	131	115	95	68		
	CVD151/9+C31500T221-Z	15	20	[m]	171	170	168	166	164	162	160	147	129	106	77		
	CVD151/10+C31500T221-Z	15	20	[m]	191	189	187	185	183	181	178	164	144	119	86		
	CVD151/11+C31500T221-Z	15	20	[m]	209	207	205	203	201	198	196	180	159	131	95		
	CVD151/12+C31500T221-Z	15	20	[m]	231	229	227	225	222	219	217	199	176	146	107		
NPSH				[m]	0,9	1,1	1,1	1,2	1,3	1,4	1,4	1,8	2,6	4,2	7,1		

M.E.I. ≥ 0.40

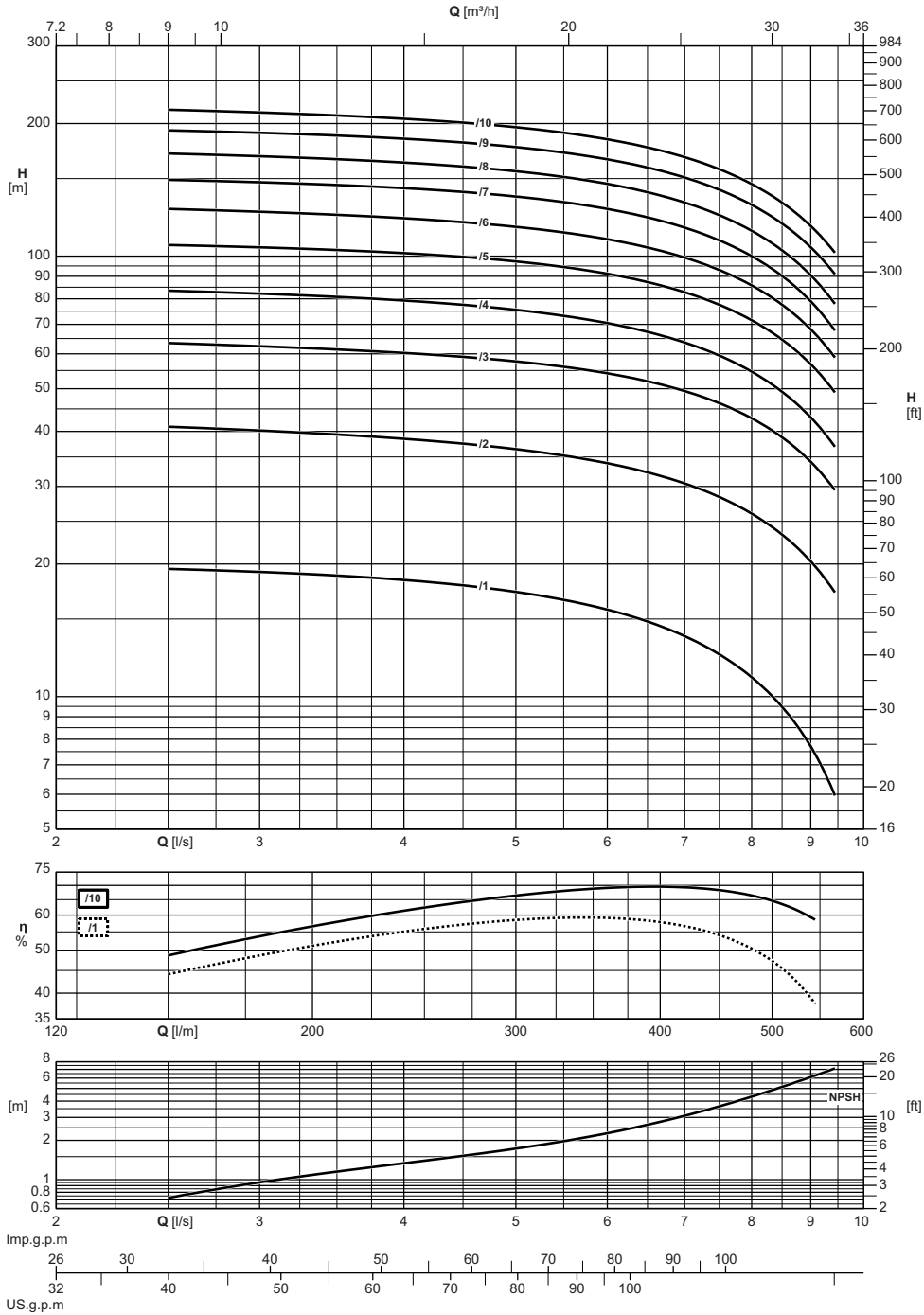

Electric pump type Electrobomba tipo Elettropompa tipo		Motor power Potencia motor Potenza motore		Capacity / Caudal / Portata													
				[l/s]	2,8	3	3,2	3,4	3,6	3,8	4	5	6	7	8	9	
				[m³/h]	10,1	10,8	11,5	12,2	13	13,7	14,4	18	21,5	25	29	32	
				[l/min]	168	180	192	204	216	228	240	300	360	420	480	540	
Single-phase Monofasica Monofase	Three-phase Trifasica Trifase	[kW]	[CV]	Total manometric head Altura manometrica total Prevalenza manometrica totale													
				[m]	19,5	19	19	19	18,5	18,5	18,5	17,5	15,5	13,5	11	7,7	
	CVD201/1+C30220T211-Z	2,2	3	[m]	19,5	19	19	19	18,5	18,5	18,5	17,5	15,5	13,5	11	7,7	
	CVD201/2+C30400T221-Z	4	5,5	[m]	40,5	40	40	39,5	39	39	38,5	36,5	34	30,5	26	20,5	
	CVD201/3+C30550T221-Z	5,5	7,5	[m]	63	62	62	62	61	61	60	58	54	49,5	43	34	
	CVD201/4+C30750T221-Z	7,5	10	[m]	83	82	82	81	81	80	79	76	70	64	55	43	
	CVD201/5+C30920T221-Z	9,2	12,5	[m]	105	105	104	104	103	102	102	97	91	83	72	57	
	CVD201/6+C31100T221-Z	11	15	[m]	127	126	125	125	124	123	122	117	109	99	86	68	
	CVD201/7+C31500T221-Z	15	20	[m]	148	147	146	146	145	144	143	137	128	116	100	79	
	CVD201/8+C31500T221-Z	15	20	[m]	170	169	168	167	165	164	163	156	146	132	114	90	
	CVD201/9+C31850T221-Z	18,5	25	[m]	192	191	190	188	187	186	185	177	166	151	131	105	
	CVD201/10+C31850T221-Z	18,5	25	[m]	213	212	211	209	208	207	205	196	184	168	146	117	
NPSH				[m]	0,9	1	1	1,1	1,2	1,3	1,3	1,7	2,3	3,1	4,3	6,1	

M.E.I. ≥ 0.40

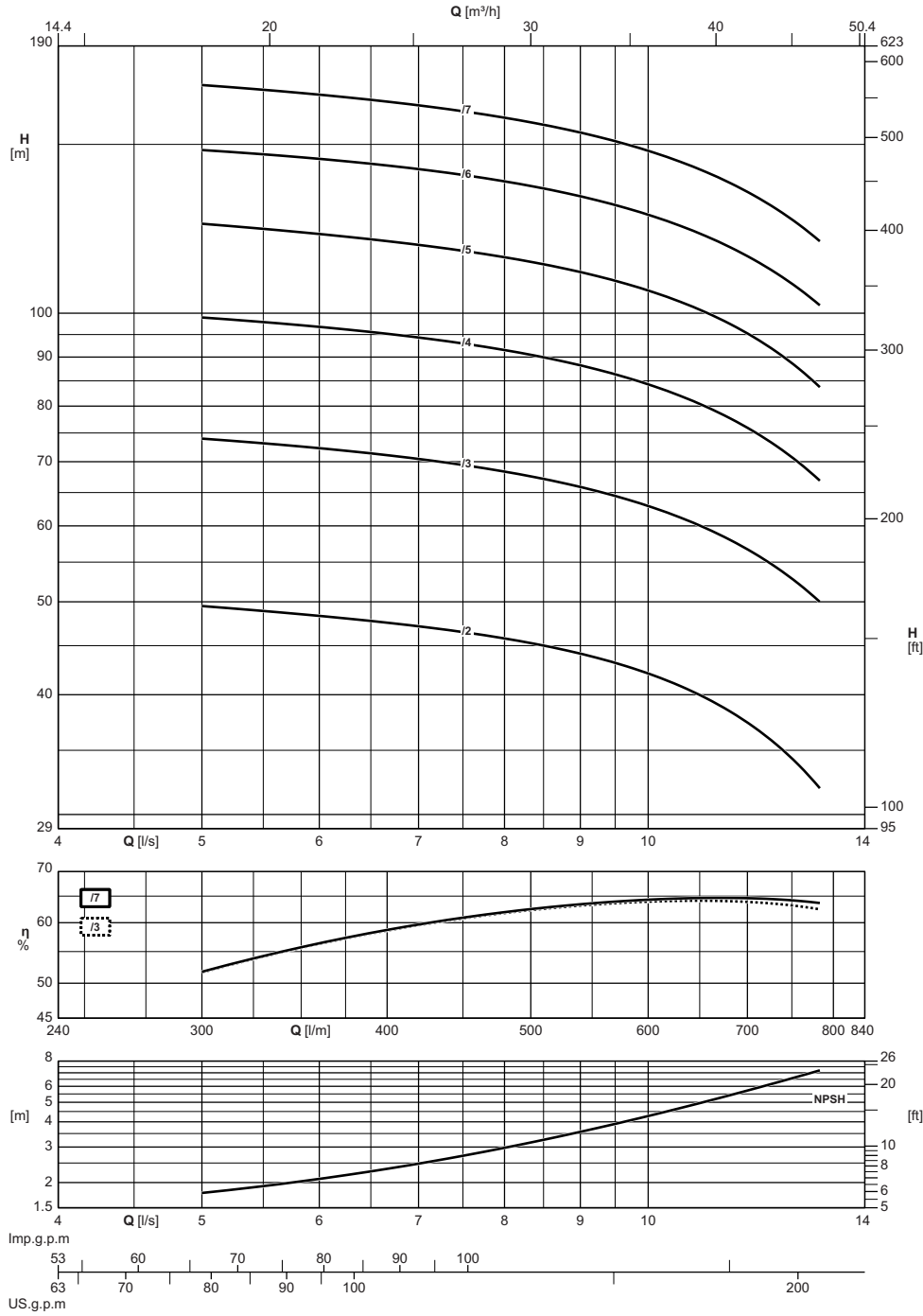

Electric pump type <i>Electrobomba tipo</i> Elettropompa tipo		Motor power <i>Potencia motor</i> Potenza motore		Capacity <i>Caudal</i> Portata												
				[l/s]	5	6	7	8	9	10	11	12	13			
				[m³/h]	18	21,5	25	29	32	36	40	43	47			
				[l/min]	300	360	420	480	540	600	660	720	780			
Single-phase <i>Monofasica</i> Monofase	Three-phase <i>Trifasica</i> Trifase	[kW]	[CV]	Total manometric head <i>Altura manometrica total</i> Prevalenza manometrica totale												
				[m]	49,5	48,5	47	46	44	42	39,5	36	32			
	CVD321/2+C30750T221-Z	7,5	10	[m]	49,5	48,5	47	46	44	42	39,5	36	32			
	CVD321/3+C31100T221-Z	11	15	[m]	74	72	71	68	66	63	59	55	50			
	CVD321/4+C31500T221-Z	15	20	[m]	99	97	94	92	88	84	80	74	67			
	CVD321/5+C31850T221-Z	18,5	25	[m]	124	121	118	114	110	106	100	93	84			
	CVD321/6+C32200T221-Z	22	30	[m]	148	145	141	137	132	127	120	112	103			
	CVD321/7+C32200T221-Z	22	30	[m]	173	169	165	160	154	148	140	131	120			
NPSH				[m]	1,8	2,1	2,5	3	3,6	4,3	5,1	6,1	7,1			

M.E.I. ≥ 0.40

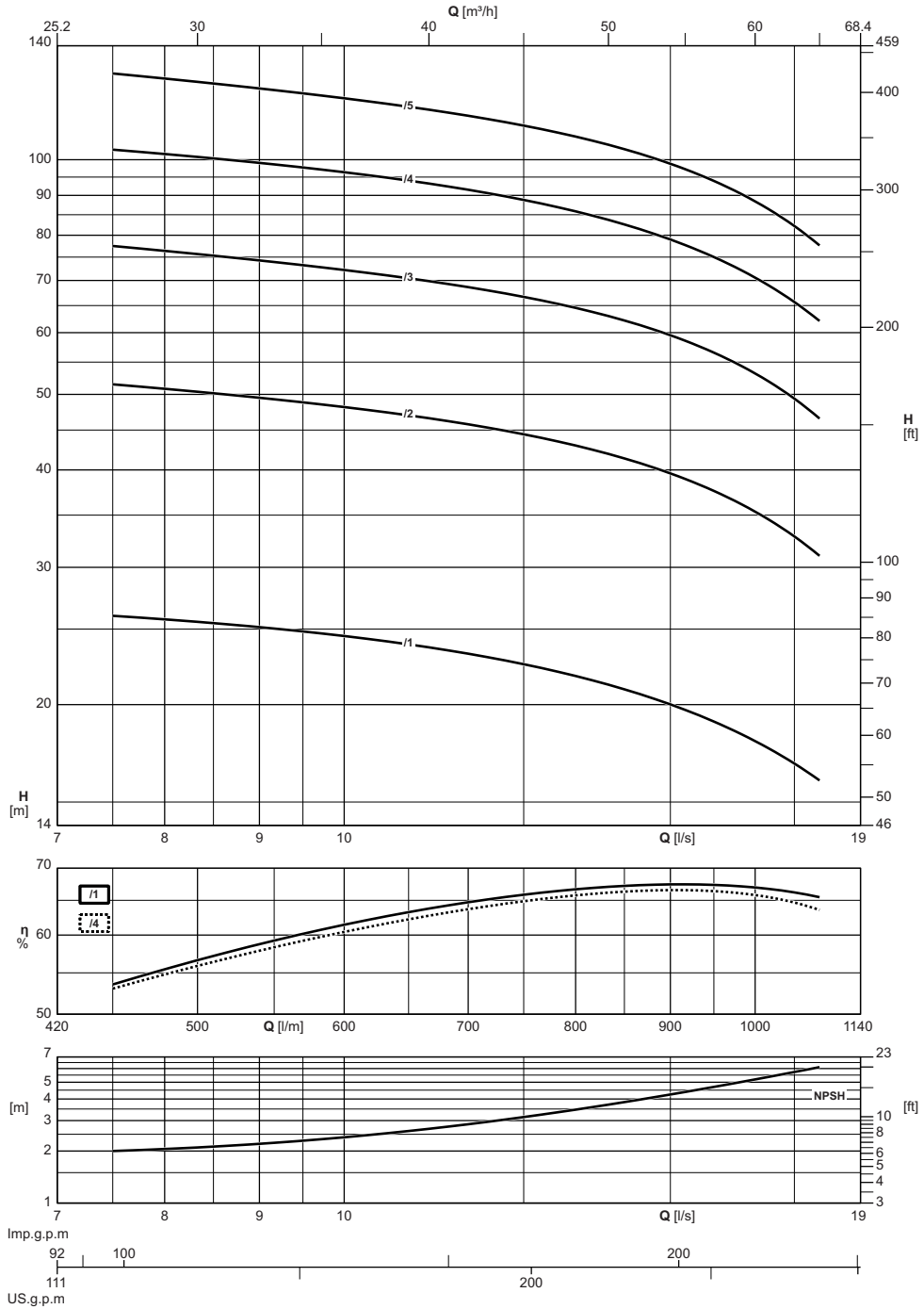

Electric pump type <i>Electrobomba tipo</i> Elettropompa tipo		Motor power <i>Potencia motor</i> Potenza motore		Capacity <i>Caudal</i> Portata													
				[l/s]	8	9	10	11	12	13	14	15	16	17	18		
				[m³/h]	29	32	36	40	43	47	50	54	58	61	65		
				[l/min]	480	540	600	660	720	780	840	900	960	1020	1080		
Single-phase <i>Monofasica</i> Monofase	Three-phase <i>Trifasica</i> Trifase	[kW]	[CV]	Total manometric head <i>Altura manometrica total</i> Prevalenza manometrica totale													
				[m]	25,5	25	24,5	24	23	22	21	20	19	17,5	16		
	CVD451/1+C30550T221-Z	5,5	7,5	[m]	25,5	25	24,5	24	23	22	21	20	19	17,5	16		
	CVD451/2+C31100T221-Z	11	15	[m]	51	49,5	48	47	45	43,5	41,5	39,5	37	34,5	31		
	CVD451/3+C31500T221-Z	15	20	[m]	76	74	72	70	68	65	63	60	56	52	47		
	CVD451/4+C31850T221-Z	18,5	25	[m]	102	99	96	94	90	87	83	79	74	69	63		
	CVD451/5+C32200T221-Z	22	30	[m]	127	123	120	116	113	109	104	99	93	86	78		
NPSH				[m]	2,1	2,2	2,4	2,7	3	3,3	3,8	4,2	4,8	5,4	6,1		
M.E.I. ≥ 0.40																	

Overall dimensions and weight
Dimensiones máximas y pesos
Dimensioni di ingombro e pesi

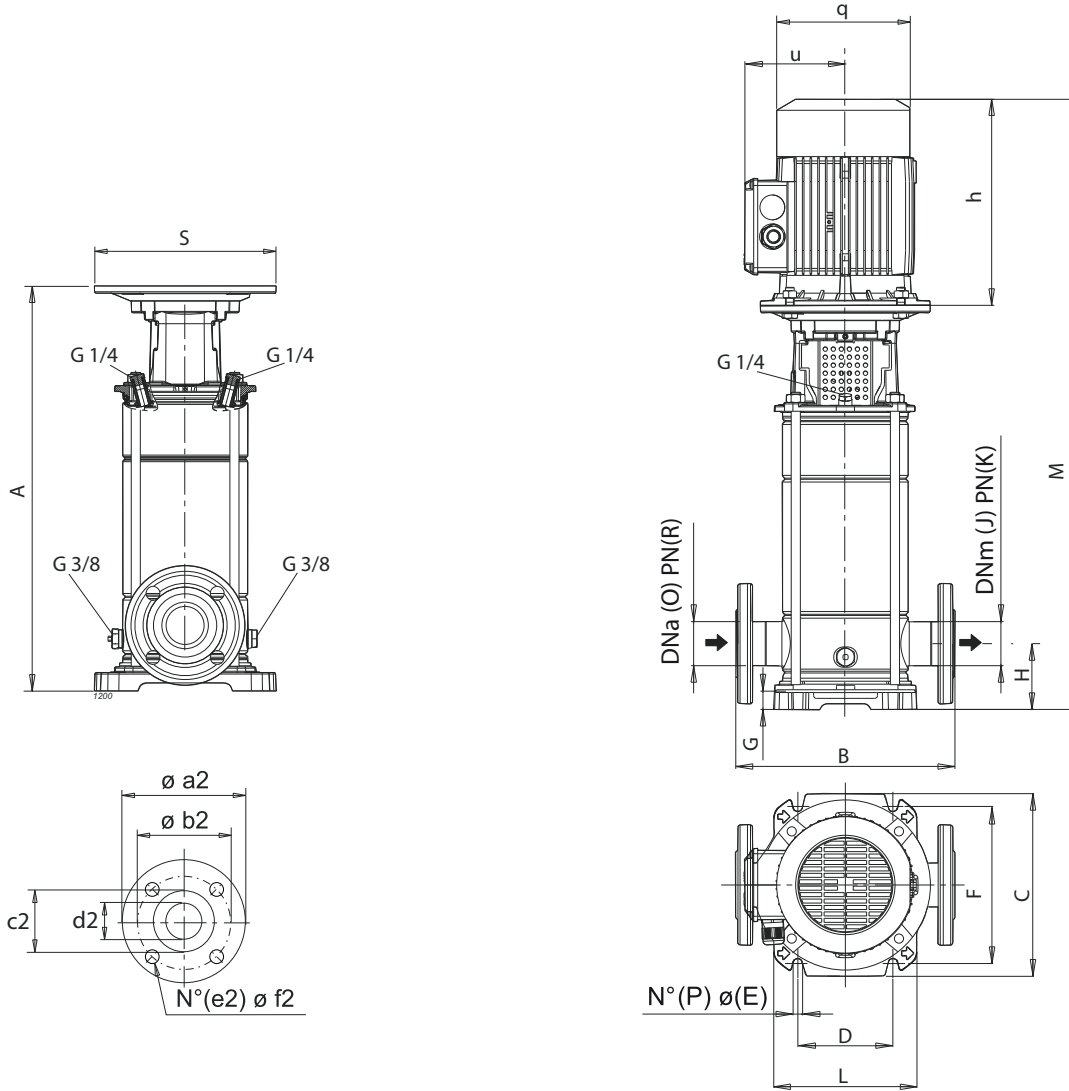

Type Tipo Tipo	A	B	C	D	E	F	G	H	J	K	L	M	O	P	R	S	h	q	u	a2	b2	c2	d2	e2	f2	Weight Peso Peso
CVD031/3+C30110T211-Z	382.5	250	205	100	13	180	35.5	75	25	25-40	165	637.5	25	4	25-40	200	255	157	127.5	115	85	65	25	4	14	32,9
CVD031/4+C30110T211-Z	382.5	250	205	100	13	180	35.5	75	25	25-40	165	637.5	25	4	25-40	200	255	157	127.5	115	85	65	25	4	14	33
CVD031/5+C30150T211-Z	406.5	250	205	100	13	180	35.5	75	25	25-40	165	661.5	25	4	25-40	200	255	157	127.5	115	85	65	25	4	14	35
CVD031/6+C30220T211-Z	430.5	250	205	100	13	180	35.5	75	25	25-40	165	725.5	25	4	25-40	200	295	157	127.5	115	85	65	25	4	14	38,9
CVD031/7+C30220T211-Z	454.5	250	205	100	13	180	35.5	75	25	25-40	165	749.5	25	4	25-40	200	295	157	127.5	115	85	65	25	4	14	39,6
CVD031/8+C30300T211-Z	478.5	250	205	100	13	180	35.5	75	25	25-40	165	789.5	25	4	25-40	250	311	188	137.5	115	85	65	25	4	14	47,8
CVD031/10+C30300T211-Z	527	250	205	100	13	180	35.5	75	25	25-40	165	838	25	4	25-40	250	311	188	137.5	115	85	65	25	4	14	49,2
CVD031/12+C30400T211-Z	575.5	250	205	100	13	180	35.5	75	25	25-40	165	886.5	25	4	25-40	250	311	188	137.5	115	85	65	25	4	14	54,9
CVD031/14+C30400T211-Z	623.5	250	205	100	13	180	35.5	75	25	25-40	165	934.5	25	4	25-40	250	311	188	137.5	115	85	65	25	4	14	56,2
CVD051/3+C30150T211-Z	382.5	250	205	100	13	180	35.5	75	32	25-40	165	637.5	32	4	25-40	200	255	157	127.5	140	100	76	32	4	19	35,4
CVD051/4+C30220T211-Z	382.5	250	205	100	13	180	35.5	75	32	25-40	165	677.5	32	4	25-40	200	295	157	127.5	140	100	76	32	4	19	38,8
CVD051/5+C30220T211-Z	406.5	250	205	100	13	180	35.5	75	32	25-40	165	701.5	32	4	25-40	200	295	157	127.5	140	100	76	32	4	19	39,4
CVD051/6+C30300T211-Z	430.5	250	205	100	13	180	35.5	75	32	25-40	165	741.5	32	4	25-40	250	311	188	137.5	140	100	76	32	4	19	46,9
CVD051/7+C30300T211-Z	454.5	250	205	100	13	180	35.5	75	32	25-40	165	765.5	32	4	25-40	250	311	188	137.5	140	100	76	32	4	19	48,3
CVD051/8+C30400T211-Z	478.5	250	205	100	13	180	35.5	75	32	25-40	165	789.5	32	4	25-40	250	311	188	137.5	140	100	76	32	4	19	53,3
CVD051/10+C30400T211-Z	527	250	205	100	13	180	35.5	75	32	25-40	165	838	32	4	25-40	250	311	188	137.5	140	100	76	32	4	19	54,6
CVD051/12+C30550T211-Z	662	250	205	100	13	180	35.5	75	32	25-40	165	1001	32	4	25-40	300	339	223	137.5	140	100	76	32	4	19	80,5
CVD051/14+C30550T211-Z	710	250	205	100	13	180	35.5	75	32	25-40	165	1049	32	4	25-40	300	339	223	137.5	140	100	76	32	4	19	81,8
CVD101/3+C30220T211-Z	411.5	280	250	130	14	215	30.5	80	40	25-40	190	706.5	40	4	25-40	200	295	157	127.5	150	110	84	40	4	19	41,1
CVD101/4+C30300T211-Z	411.5	280	250	130	14	215	30.5	80	40	25-40	190	722.5	40	4	25-40	250	311	188	137.5	150	110	84	40	4	19	48,8
CVD101/5+C30400T211-Z	441.5	280	250	130	14	215	30.5	80	40	25-40	190	752.5	40	4	25-40	250	311	188	137.5	150	110	84	40	4	19	53
CVD101/6+C30400T211-Z	471.5	280	250	130	14	215	30.5	80	40	25-40	190	782.5	40	4	25-40	250	311	188	137.5	150	110	84	40	4	19	55
CVD101/7+C30550T211-Z	588	280	250	130	14	215	30.5	80	40	25-40	190	927	40	4	25-40	300	339	223	159.5	150	110	84	40	4	19	80,3
CVD101/8+C30550T211-Z	618.5	280	250	130	14	215	30.5	80	40	25-40	190	957.5	40	4	25-40	300	339	223	159.5	150	110	84	40	4	19	81,2
CVD101/10+C30750T211-Z	678.5	280	250	130	14	215	30.5	80	40	25-40	190	1017.5	40	4	25-40	300	339	223	159.5	150	110	84	40	4	19	88
CVD101/11+C30750T211-Z	708.5	280	250	130	14	215	30.5	80	40	25-40	190	1047.5	40	4	25-40	300	339	223	159.5	150	110	84	40	4	19	88,8

Overall dimensions and weight
Dimensiones máximas y pesos
Dimensioni di ingombro e pesi

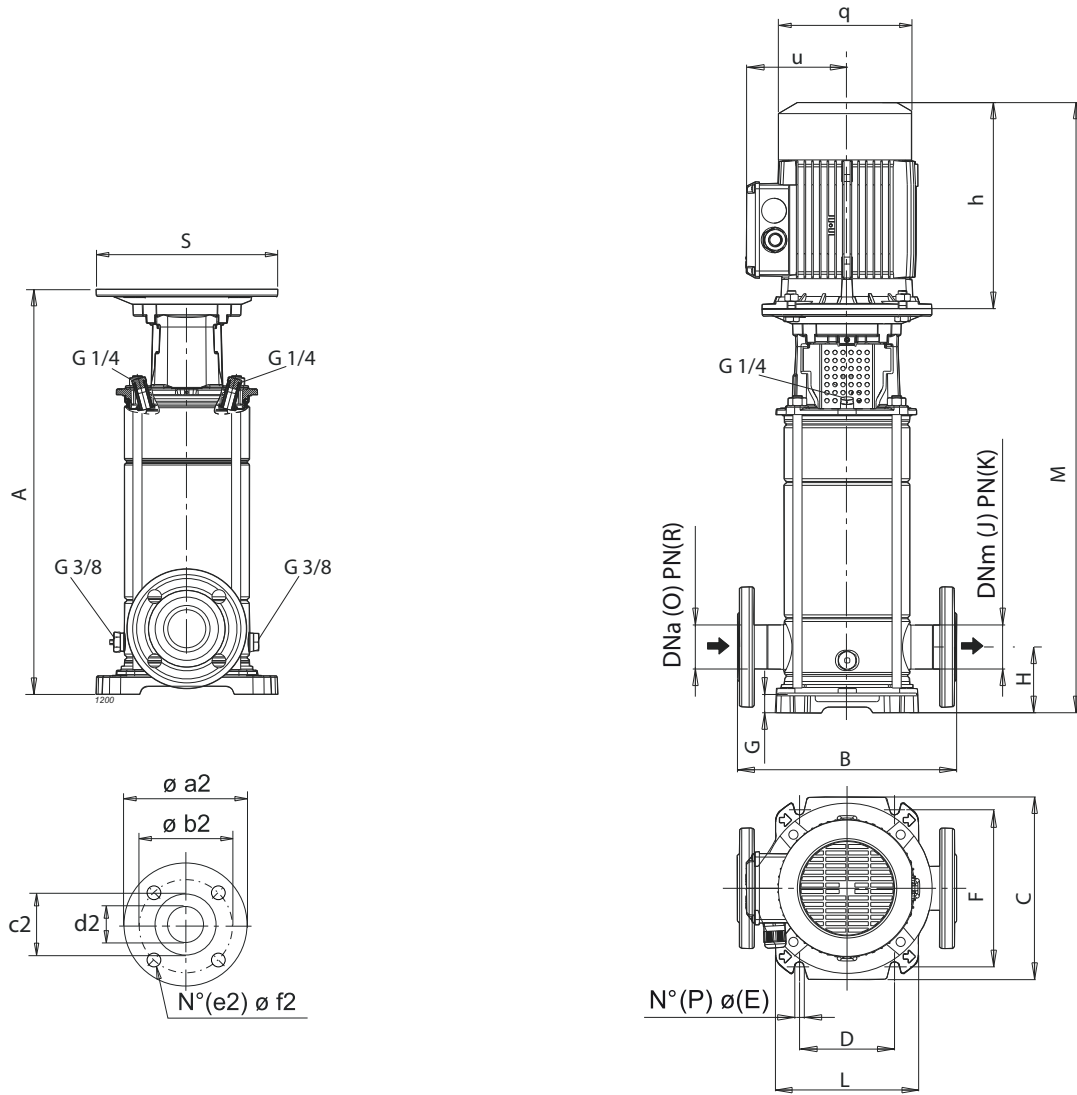

Type Tipo Tipo	A	B	C	D	E	F	G	H	J	K	L	M	O	P	R	S	h	q	u	a2	b2	c2	d2	e2	f2	Weight Peso Peso
CVD151/1+C30150T211-Z	438	300	250	130	13	215	25	90	50	25	196	733	50	4	25	200	295	157	127.5	165	125	99	50	4	19	40,7
CVD151/2+C30300T211-Z	438	300	250	130	13	215	25	90	50	25	196	749	50	4	25	250	311	188	137.5	165	125	99	50	4	19	53,3
CVD151/3+C30400T221-Z	486	300	250	130	13	215	25	90	50	25	196	797	50	4	25	250	311	188	137.5	165	125	99	50	4	19	58,8
CVD151/4+C30550T221-Z	597	300	250	130	13	215	25	90	50	25	196	936	50	4	25	300	339	223	159.5	165	125	99	50	4	19	85
CVD151/5+C30750T221-Z	645	300	250	130	13	215	25	90	50	25	196	984	50	4	25	300	339	223	159.5	165	125	99	50	4	19	87,7
CVD151/6+C30750T221-Z	693	300	250	130	13	215	25	90	50	25	196	1032	50	4	25	300	339	223	159.5	165	125	99	50	4	19	92
CVD151/7+C30920T221-Z	771	300	250	130	13	215	25	90	50	25	196	1184	50	4	25	350	413	263.4	186	165	125	99	50	4	19	112
CVD151/8+C31100T221-Z	819	300	250	130	13	215	25	90	50	25	196	1278	50	4	25	350	459	263.4	186	165	125	99	50	4	19	129,5
CVD151/9+C31500T221-Z	867	300	250	130	13	215	25	90	50	25	196	1351	50	4	25	350	484	263.4	186	165	125	99	50	4	19	156,9
CVD151/10+C31500T221-Z	915	300	250	130	13	215	25	90	50	25	196	1399	50	4	25	350	484	263.4	186	165	125	99	50	4	19	158,4
CVD151/11+C31500T221-Z	963	300	250	130	13	215	25	90	50	25	196	1447	50	4	25	350	484	263.4	186	165	125	99	50	4	19	159,8
CVD151/12+C31500T221-Z	1011	300	250	130	13	215	25	90	50	25	196	1495	50	4	25	350	484	263.4	186	165	125	99	50	4	19	161,3
CVD201/1+C30220T211-Z	438	300	250	130	13	215	25	90	50	25	196	733	50	4	25	200	295	157	127.5	165	125	99	50	4	19	45,2
CVD201/2+C30400T221-Z	438	300	250	130	13	215	25	90	50	25	196	749	50	4	25	250	311	188	137.5	165	125	99	50	4	19	56,7
CVD201/3+C30550T221-Z	549	300	250	130	13	215	25	90	50	25	196	888	50	4	25	300	339	223	159.5	165	125	99	50	4	19	82
CVD201/4+C30750T221-Z	597	300	250	130	13	215	25	90	50	25	196	936	50	4	25	300	339	223	159.5	165	125	99	50	4	19	89
CVD201/5+C30920T221-Z	675	300	250	130	13	215	25	90	50	25	196	1088	50	4	25	350	413	263.4	186	165	125	99	50	4	19	109
CVD201/6+C31100T221-Z	723	300	250	130	13	215	25	90	50	25	196	1182	50	4	25	350	459	263.4	186	165	125	99	50	4	19	126,6
CVD201/7+C31500T221-Z	771	300	250	130	13	215	25	90	50	25	196	1255	50	4	25	350	484	263.4	186	165	125	99	50	4	19	154
CVD201/8+C31500T221-Z	819	300	250	130	13	215	25	90	50	25	196	1303	50	4	25	350	484	263.4	186	165	125	99	50	4	19	155,5
CVD201/9+C31850T221-Z	867	300	250	130	13	215	25	90	50	25	196	1405	50	4	25	350	538	315	206	165	125	99	50	4	19	178,5
CVD201/10+C31850T221-Z	915	300	250	130	13	215	25	90	50	25	196	1453	50	4	25	350	538	315	206	165	125	99	50	4	19	182

Overall dimensions and weight
Dimensiones máximas y pesos
Dimensioni di ingombro e pesi

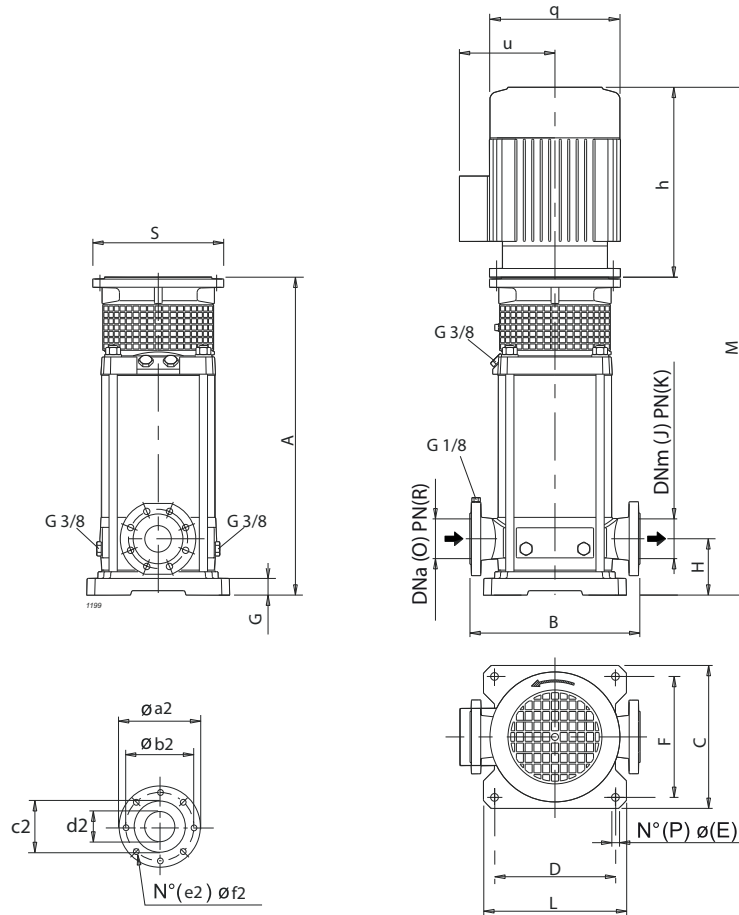

Type Tipo Tipo	A	B	C	D	E	F	G	H	J	K	L	M	O	P	R	S	h	q	u	a2	b2	c2	d2	e2	f2	Weight Peso Peso
CVD321/2+C30750T221-Z	427	320	260	220	14	220	35	105	65	25-40	260	766	65	4	25-40	300	339	223	159.5	185	145	118	65	8	19	95,6
CVD321/3+C31100T221-Z	473	320	260	220	14	220	35	105	65	25-40	260	932	65	4	25-40	350	459	263.4	186	185	145	118	65	8	19	134
CVD321/4+C31500T221-Z	549	320	260	220	14	220	35	105	65	25-40	260	1033	65	4	25-40	350	484	263.4	186	185	145	118	65	8	19	161
CVD321/5+C31850T221-Z	595	320	260	220	14	220	35	105	65	25-40	260	1133	65	4	25-40	350	538	315	206	185	145	118	65	8	19	184,5
CVD321/6+C32200T221-Z	641	320	260	220	14	220	35	105	65	25-40	260	1179	65	4	25-40	350	538	315	206	185	145	118	65	8	19	191,3
CVD321/7+C32200T221-Z	687	320	260	220	14	220	35	105	65	25-40	260	1225	65	4	25-40	350	538	315	206	185	145	118	65	8	19	194,9
CVD451/1+C30550T221-Z	431	320	260	220	14	220	35	105	80	25-40	260	770	80	4	25-40	300	339	223	159.5	200	160	132	80	8	19	93
CVD451/2+C31100T221-Z	496	320	260	220	14	220	35	105	80	25-40	260	955	80	4	25-40	350	459	263.4	186	200	160	132	80	8	19	135
CVD451/3+C31500T221-Z	557	320	260	220	14	220	35	105	80	25-40	260	1041	80	4	25-40	350	484	263.4	186	200	160	132	80	8	19	163
CVD451/4+C31850T221-Z	618	320	260	220	14	220	35	105	80	25-40	260	1156	80	4	25-40	350	538	315	206	200	160	132	80	8	19	186
CVD451/5+C32200T221-Z	680	320	260	220	14	220	35	105	80	25-40	260	1218	80	4	25-40	350	538	315	206	200	160	132	80	8	19	196,5

MEI = 0.4 for Multistage Vertical 2900rpm

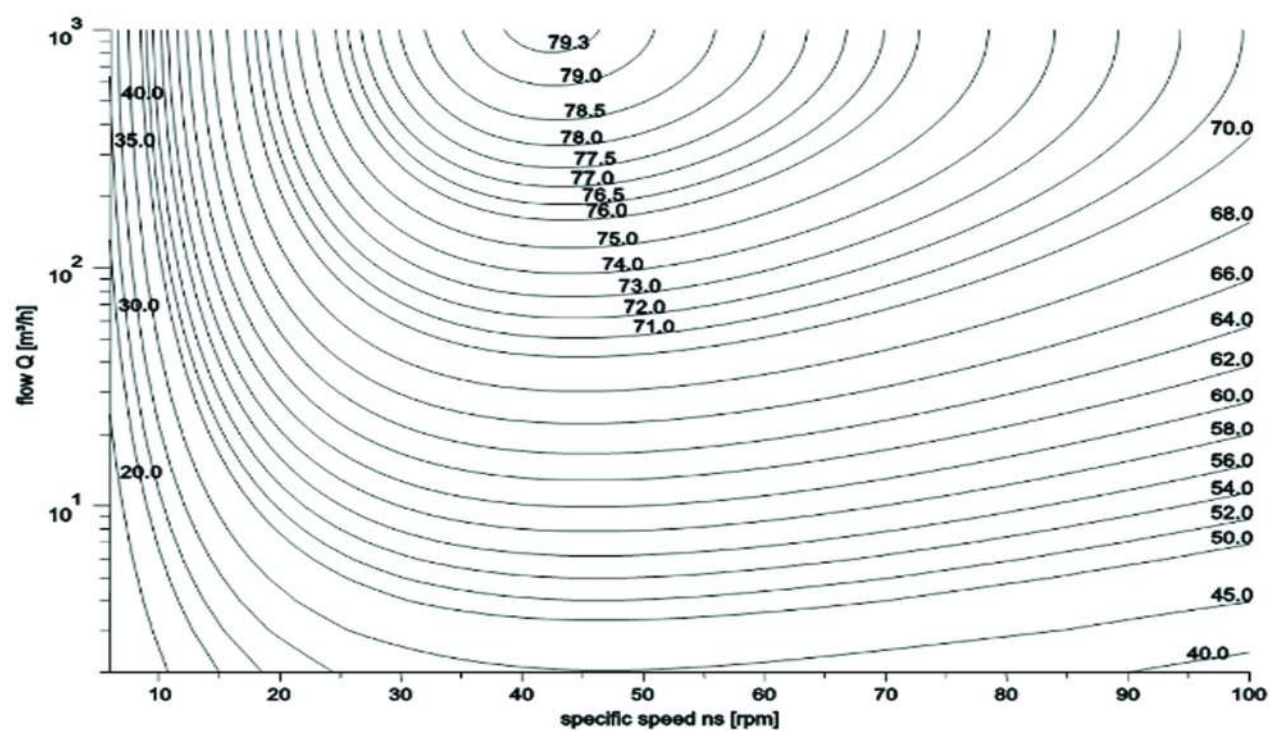

MEI=0.7 for Mutistage Vertical 2900 rpm

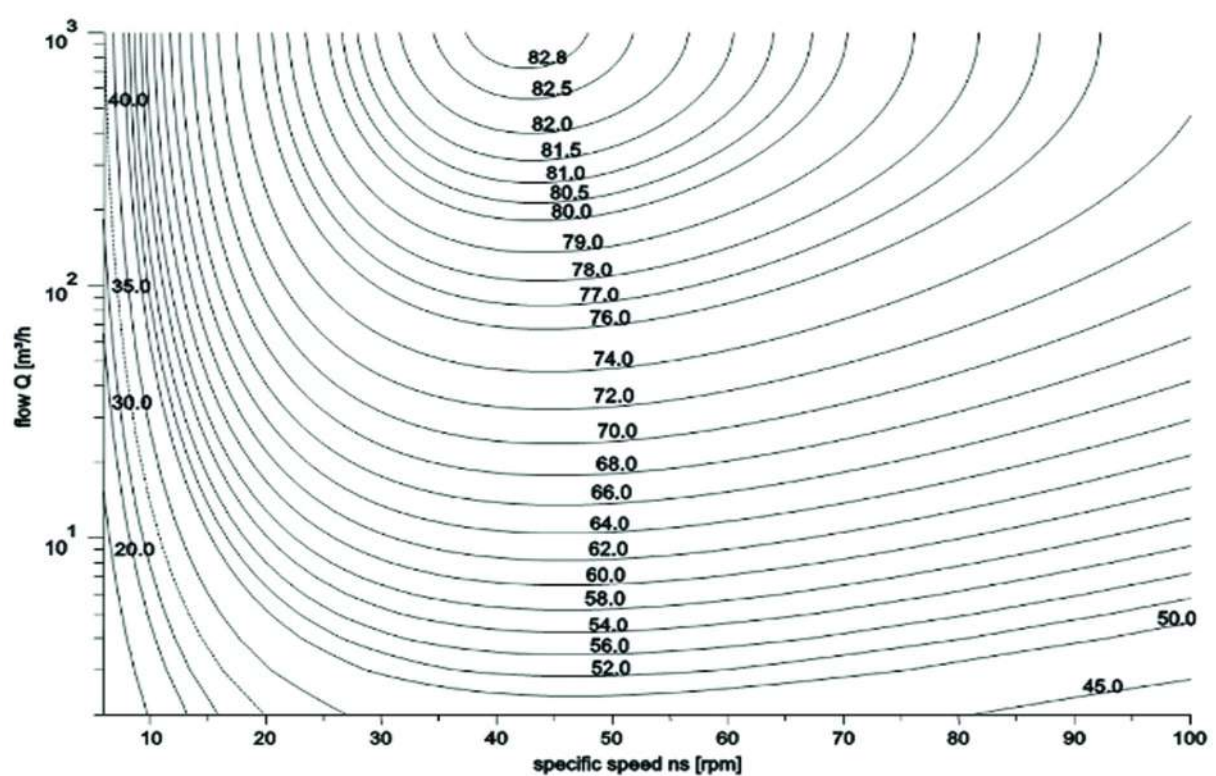

caprari

The dimensions have an indicative value. Executive drawing will be supplied on request upon order.
CAPRARI S.p.A. reserves the right to make changes to improve its products at any time and without any notice

Las dimensiones tienen carácter indicativo. El diseño ejecutivo se suministrará bajo pedido en fase de orden.
CAPRARI S.p.A. se reserva el derecho de efectuar modificaciones para mejorar sus productos en cualquier momento sin obligación de aviso previo.

Le dimensioni hanno valore indicativo. Il disegno esecutivo sarà fornito su richiesta in fase d'ordine.
CAPRARI S.p.A. si riserva facoltà di apportare modifiche atte a migliorare i propri prodotti in qualsiasi momento e senza preavviso alcuno.