

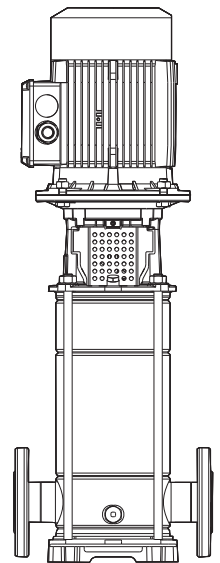

MULTISTAGE VERTICAL ELECTRIC PUMPS
ELECTROPOMPES MULTIETAGES VERTICALES
ELETTROPOMPE MULTISTADIO VERTICALI

CVD

Poles
Poles 2 50 Hz
Poli



caprari

pumping power

ISO 9001
ISO 14001
ISO 45001
BUREAU VERITAS
Certification



PUMP CODING - IDENTIFICATION DU SIGLE - ESEMPLIFICAZIONE SIGLA

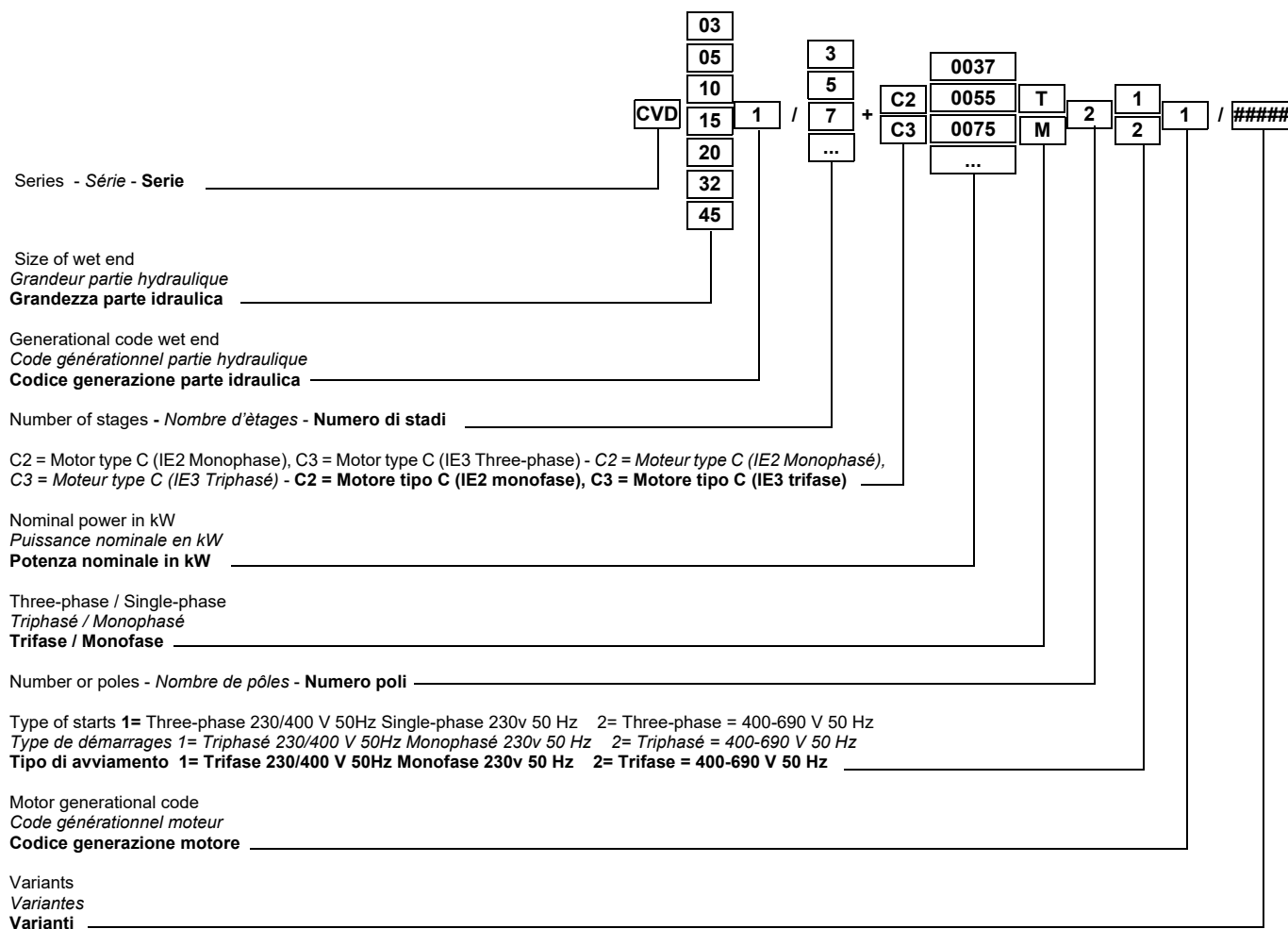

SPECIFICATIONS - CARACTÉRISTIQUE - CARATTERISTICHE

	In line	En ligne		In line
• Inlet/outlet ports	In line	• Orifices d'aspiration et refoulement	En ligne	• Bocche ingresso/uscita
• Seal	Mechanical	• Garniture	Mécanique	• Tenuta
• Max. temperature of pump liquid	+110°C	• Température max. du liquide pompé	+110°C	• Temperatura max. liquido sollevato
• Voltage	Eurovoltage	• Tension	Eurotension	• Tensione
• Frequency	Multi-frequency	• Fréquence	Multifréquence	• Frequenza
• Efficiency class	IE3	• Classe de rendement	IE3	• Classe di efficienza
• IP	55	• IP	55	• IP
• Poles	2	• Pôles	2	• Poli
• VSD (inverter)	Compatible	• VSD (variateur de fréquence)	Compatible	• VSD (inverter)

TOLERANCES - TOLERANCES - TOLLERANZE

Given specifications relate to cold water (15 °C) at a pressure of 1 bar (atmospheric) and are guaranteed as for all series pumps according to UNI/ISO 9906 Grade 3B. The data given in the catalogue refer to liquids with a volume mass of 1 kg/dm³ and kinematic viscosity of not more than 1 mm²/s.

Les caractéristiques de fonctionnement sont relevées avec eau froide (15 °C) à la pression atmosphérique (1 bar) et sont garanties, en tenant compte qu'il s'agit de pompes construites en série, selon les normes UNI/ISO 9906 Niveau 3B. Les données du catalogue se réfèrent à des liquides ayant une densité de 1 kg/dm³ et avec une viscosité cinématique égale ou inférieure à 1 mm²/s.

Le caratteristiche di funzionamento sono state rilevate con acqua fredda (15 °C) alla pressione atmosferica (1 bar) e vengono garantite, trattandosi di pompe costruite in serie, secondo le norme UNI/ISO 9906 grado 3B. I dati di catalogo si riferiscono a liquidi con densità di 1kg/dm³ e con viscosità cinematica non superiore a 1mm²/s.

031
 051
 101
 151
 201

321
 451

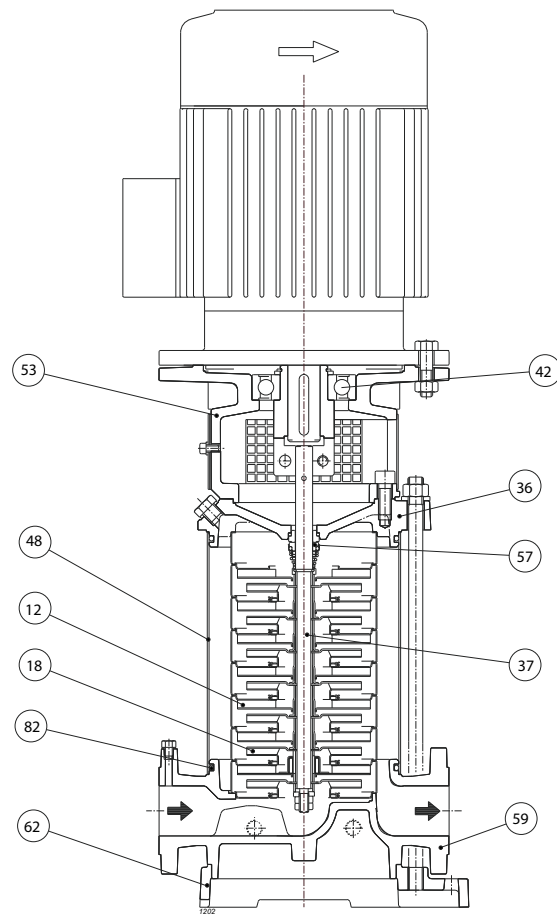
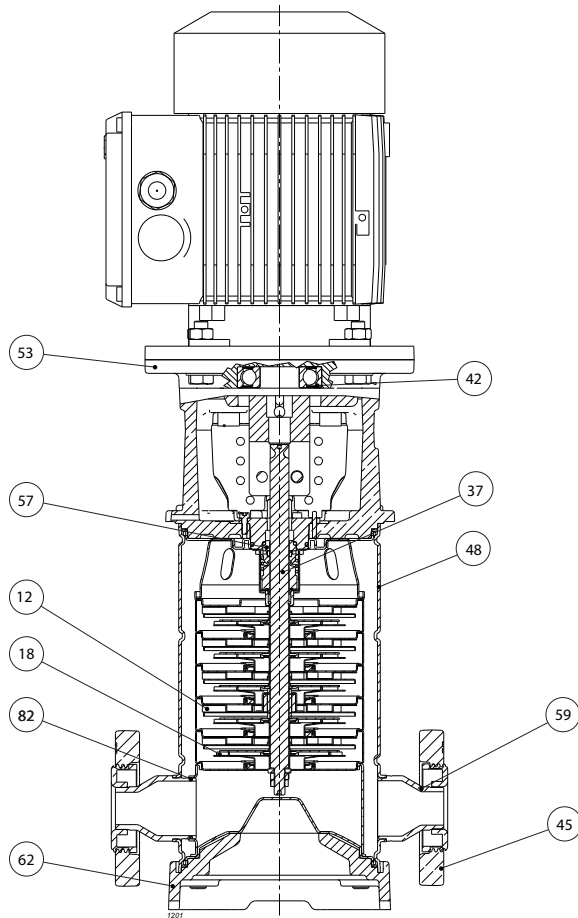

Pos.	Parts	Materials	Nomenclature	Matériaux	Nomenclatura	Materiale
12	Diffuser	Stainless steel	Diffuseur	Acier inox	Diffusore	Acciaio inox
18	Impeller	Stainless steel	Roue	Acier inox	Girante	Acciaio inox
36	Pump head (321-451)	Cast iron	Tête de pompe (321-451)	Fonte grise	Testata pompa (321-451)	Ghisa grigia
37	Shaft	Stainless steel	Arbre	Acier inox	Albero	Acciaio inox
42	Bearing	Tungsten carbide/ceramic	Coussinet	Carbure de tungstène/ céramique	Cuscinetto	Carburo di tungsteno/ ceramica
45	Inlet/Outlet Flanges (031-051-101-151-201)	Cast iron	Brides d'aspiration et refoulement (031-051-101-151-201)	Fonte grise	Flange ingresso/uscita (031-051-101-151-201)	Ghisa grigia
48	Stage casing	Stainless steel	Corps d'etage	Acier inox	Camicia esterna	Acciaio inox
53	Lantern bracket	Cast iron	Lanterne-support	Fonte grise	Supporto di collegamento	Ghisa grigia
57	Mechanical seal (031-051-101-151-201)	Silicon carbide/Carbon/ Rubber	Garniture mécanique (031-051-101-151-201)	Carbure de silicium/Charbon/ Caoutchouc	Tenuta meccanica (031-051-101-151-201)	Carburo di silicio/Carbone/ Gomma
57	Mechanical seal (321-451)	Tungsten carbide/Carbon/ Rubber	Garniture mécanique (321-451)	Carbure de tungstène/ Charbon /Caoutchouc	Tenuta meccanica (321-451)	Carburo di tungsteno/ Carbone/Gomma
59	Pump casing	Stainless steel	Corps de pomp	Acier inox	Corpo pompa	Acciaio inox
59	Pump casing (321-451)	Cast iron	Corps de pomp (321-451)	Fonte grise	Corpo pompa (321-451)	Ghisa grigia
62	Base plate	Cast iron	Plaque de base	Fonte grise	Piastra base	Ghisa grigia
82	Seal ring	Rubber	Bague détachéité	Caoutchouc	Anello di tenuta	Gomma

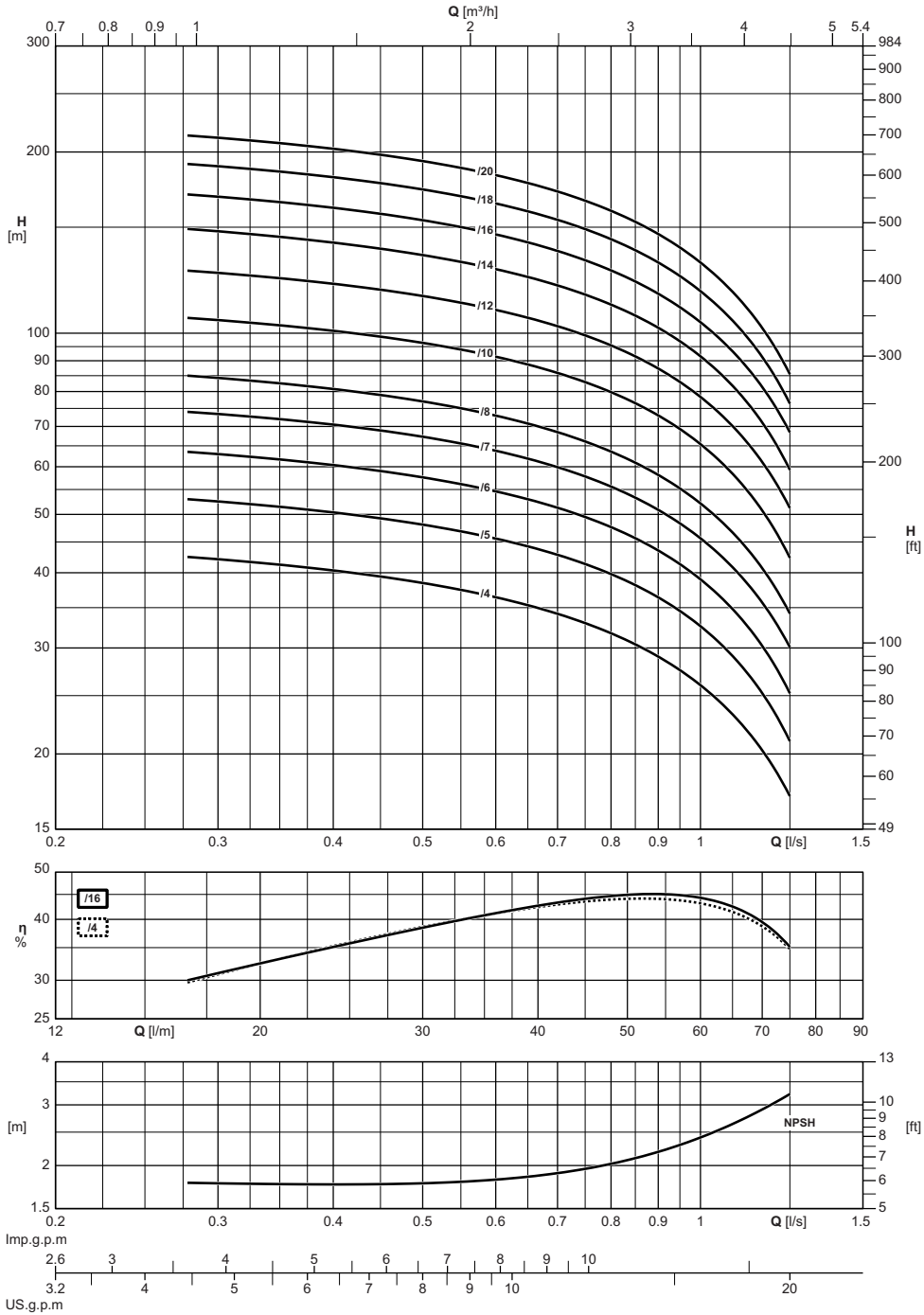

Electric pump type Electropompe type Elettropompa tipo		Motor power Puiss. moteur Potenza motore		Capacity / Debit / Portata												
				[l/s]	0,3	0,4	0,5	0,6	0,7	0,8	0,9	1	1,2			
Single-phase Monofasé Monofase	Three-phase Triphasé Trifase	[kW]	[CV]	[m³/h]	1,1	1,4	1,8	2,2	2,5	2,9	3,2	3,6	4,3			
				[l/min]	18	24	30	36	42	48	54	60	72			
				Total manometric head Hauteur manométrique totale Prevalenza manometrica totale												
				[m]	42	40,5	38,5	36,5	34	31,5	29	26	19			
CVD031/4+C20075M211-V	CVD031/4+C30075T211-V	0,75	1	[m]	42	40,5	38,5	36,5	34	31,5	29	26	19			
CVD031/5+C20075M211-V	CVD031/5+C30075T211-V	0,75	1	[m]	53	50	48	45,5	43	40	36,5	32,5	23,5			
CVD031/6+C20110M211-V	CVD031/6+C30110T211-V	1,1	1,5	[m]	63	60	58	55	51	47,5	43,5	39	28,5			
CVD031/7+C20110M211-V	CVD031/7+C30110T211-V	1,1	1,5	[m]	73	71	67	64	60	56	51	45,5	33,5			
	CVD031/8+C30150T211-V	1,5	2	[m]	84	81	77	73	69	64	58	52	38			
	CVD031/10+C30150T211-V	1,5	2	[m]	105	101	96	91	86	80	73	65	47,5			
	CVD031/12+C30220T211-V	2,2	3	[m]	126	121	115	109	103	95	87	78	57			
	CVD031/14+C30220T211-V	2,2	3	[m]	148	141	135	128	120	112	102	92	67			
	CVD031/16+C30300T211-V	3	4	[m]	169	162	154	146	137	127	116	104	76			
	CVD031/18+C30300T211-V	3	4	[m]	189	182	173	164	154	143	131	117	86			
	CVD031/20+C30300T211-V	3	4	[m]	211	202	193	183	172	160	146	131	96			
NPSH				[m]	1,8	1,8	1,8	1,8	1,9	2	2,2	2,4	3			

M.E.I. ≥ 0.40

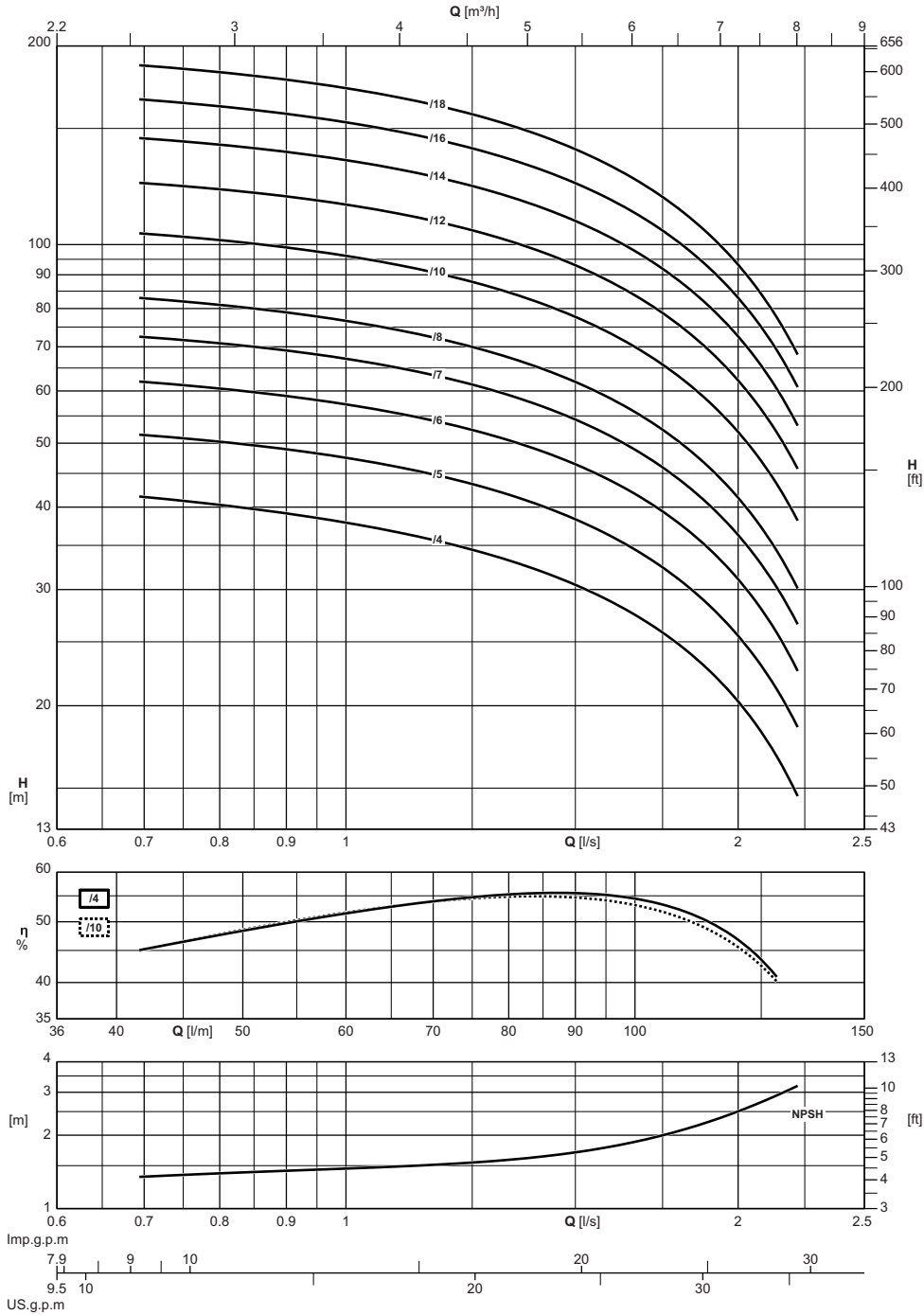

Electric pump type Electropompe type Elettropompa tipo		Motor power Puiss. moteur Potenza motore		Capacity / Debit / Portata												
				[l/s]	0,7	0,8	0,9	1	1,2	1,4	1,6	1,8	2			
Single-phase Monofase	Three-phase Triphasè Trifase	[kW]	[CV]	[m³/h]	2,5	2,9	3,2	3,6	4,3	5	5,8	6,5	7,2			
				[l/min]	42	48	54	60	72	84	96	108	120			
				Total manometric head Hauteur manométrique totale Prevalenza manometrica totale												
CVD051/4+C20110M211-V	CVD051/4+C30110T211-V	1,1	1,5	[m]	41,5	40,5	39	38	35	32	28,5	25	20,5			
CVD051/5+C20110M211-V	CVD051/5+C30110T211-V	1,1	1,5	[m]	51	50	49	47,5	44	40,5	36	31	25,5			
	CVD051/6+C30150T211-V	1,5	2	[m]	62	61	59	57	53	49	44	38	31			
	CVD051/7+C30150T211-V	1,5	2	[m]	72	71	69	67	63	57	51	44	36,5			
	CVD051/8+C30220T211-V	2,2	3	[m]	83	81	79	77	71	65	58	50	41,5			
	CVD051/10+C30220T211-V	2,2	3	[m]	104	102	99	96	90	82	73	63	52			
	CVD051/12+C30300T211-V	3	4	[m]	124	121	118	115	107	98	88	76	62			
	CVD051/14+C30300T211-V	3	4	[m]	145	142	138	134	125	115	102	88	73			
	CVD051/16+C30400T221-V	4	5,5	[m]	166	162	158	153	143	131	117	101	83			
	CVD051/18+C30400T221-V	4	5,5	[m]	187	183	178	173	161	147	131	113	93			
NPSH				[m]	1,4	1,4	1,4	1,5	1,5	1,6	1,8	2,1	2,5			

M.E.I. ≥ 0.40

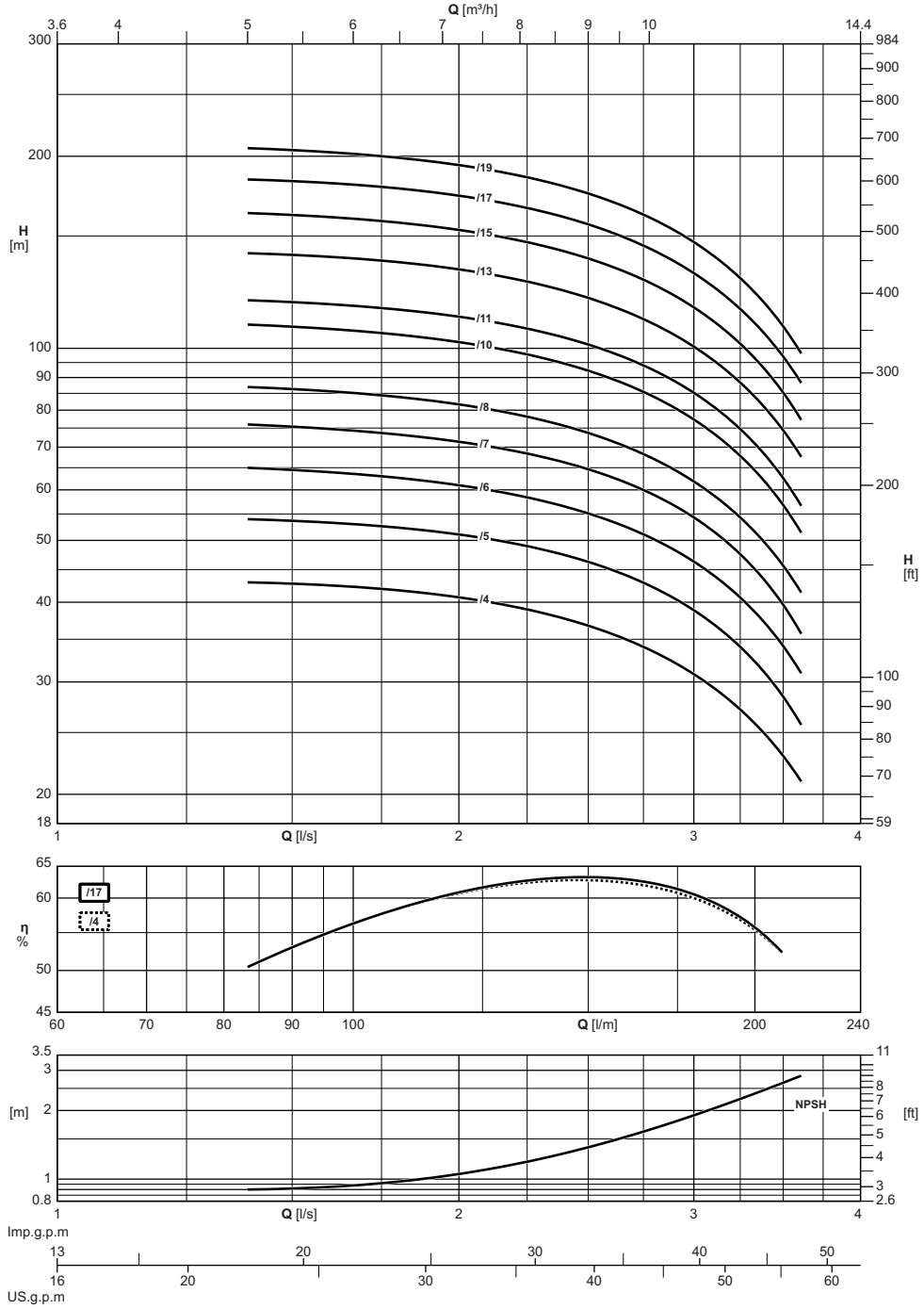

Electric pump type Electropompe type Elettropompa tipo		Motor power Puiss. moteur Potenza motore		Capacity / Debit / Portata												
				[l/s]	1,4	1,6	1,8	2	2,2	2,4	2,6	2,8	3	3,2	3,4	3,6
		[kW]	[CV]	[m³/h]	5	5,8	6,5	7,2	7,9	8,6	9,4	10,1	10,8	11,5	12,2	13
				[l/min]	84	96	108	120	132	144	156	168	180	192	204	216
Single-phase Monophasé Monofase	Three-phase Triphasé Trifase	Total manometric head Hauteur manométrique totale Prevalenza manometrica totale														
		[m]	43	42,5	41,5	40,5	39,5	37,5	35,5	33,5	31	28	24,5	21		
	CVD101/4+C30150T211-V	1,5	2	[m]	43	42,5	41,5	40,5	39,5	37,5	35,5	33,5	31	28	24,5	21
	CVD101/5+C30220T211-V	2,2	3	[m]	54	53	52	51	49,5	47,5	45	42	39	35	31	26
	CVD101/6+C30220T211-V	2,2	3	[m]	65	64	63	61	59	57	54	50	46,5	42	37	31,5
	CVD101/7+C30300T211-V	3	4	[m]	76	75	73	71	69	66	63	59	54	49	43	36
	CVD101/8+C30300T211-V	3	4	[m]	87	86	84	82	79	76	72	67	62	56	49	42
	CVD101/10+C30400T221-V	4	5,5	[m]	109	107	105	102	99	95	90	84	77	70	61	52
	CVD101/11+C30400T221-V	4	5,5	[m]	119	117	115	112	108	104	99	92	85	77	68	57
	CVD101/13+C30550T221-V	5,5	7,5	[m]	141	139	137	133	129	123	117	109	101	91	80	68
	CVD101/15+C30550T221-V	5,5	7,5	[m]	163	161	157	153	148	142	134	126	116	105	92	78
	CVD101/17+C30750T221-V	7,5	10	[m]	184	182	178	173	168	160	152	142	131	119	105	89
	CVD101/19+C30750T221-V	7,5	10	[m]	206	203	199	194	187	179	170	159	147	133	117	99
NPSH				[m]	0,9	0,9	1	1,1	1,2	1,3	1,5	1,7	1,9	2,2	2,5	2,8

M.E.I. ≥ 0.40

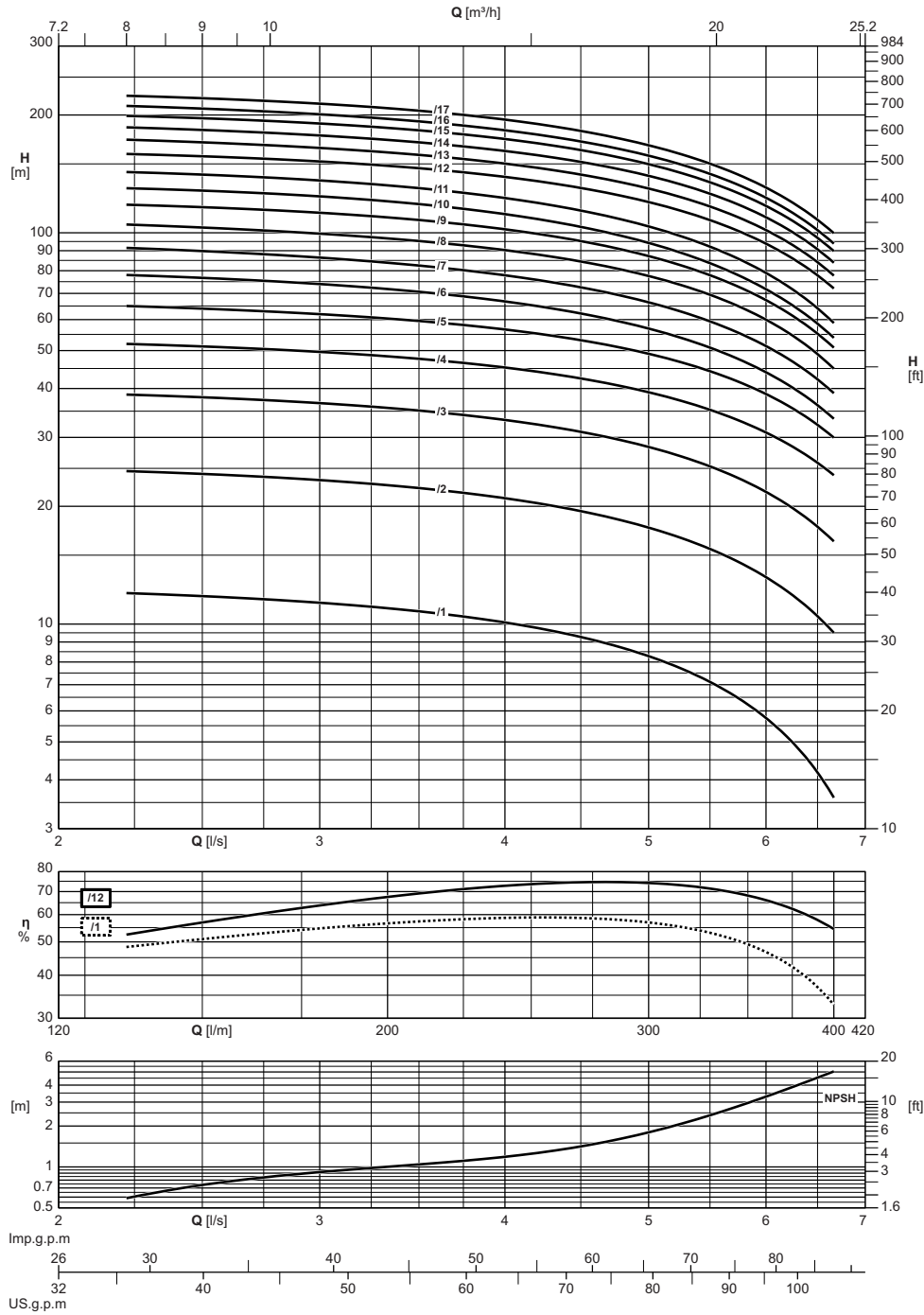

Electric pump type Electropompe type Elettropompa tipo		Motor power Puiss. moteur Potenza motore		Capacity / Debit / Portata													
				[l/s]	2,4	2,6	2,8	3	3,2	3,4	3,6	3,8	4	5	6		
		[kW]	[CV]	[m³/h]	8,6	9,4	10,1	10,8	11,5	12,2	13	13,7	14,4	18	21,5		
				[l/min]	144	156	168	180	192	204	216	228	240	300	360		
		Total manometric head / Hauteur manometrique totale / Prevalenza manometrica totale															
Single-phase / Monophasé/ Monofase	Three-phase / Triphasé Trifase																
	CVD151/1+C30110T211-V	1,1	1,5	[m]	12	11,5	11,5	11,5	11	11	10,5	10,5	10	8,3	5,8		
	CVD151/2+C30150T211-V	1,5	2	[m]	24,5	24	23,5	23,5	23	22,5	22	21,5	21	17,5	13		
	CVD151/3+C30220T211-V	2,2	3	[m]	38	37,5	37	36,5	36	35,5	35	34	33	28,5	22		
	CVD151/4+C30300T211-V	3	4	[m]	52	51	50	49,5	49	48	47	46,5	45	39	31		
	CVD151/5+C30400T221-V	4	5,5	[m]	64	64	63	62	61	60	59	58	57	49	38,5		
	CVD151/6+C30550T221-V	5,5	7,5	[m]	77	76	75	74	73	71	70	68	67	57	44		
	CVD151/7+C30550T221-V	5,5	7,5	[m]	90	89	88	86	85	83	82	80	78	66	51		
	CVD151/8+C30550T221-V	5,5	7,5	[m]	104	102	101	100	98	96	94	92	90	78	60		
	CVD151/9+C30750T221-V	7,5	10	[m]	117	116	114	113	111	109	107	105	102	87	67		
	CVD151/10+C30750T221-V	7,5	10	[m]	129	127	126	124	122	120	117	114	112	94	72		
	CVD151/11+C30920T221-V	9,2	12,5	[m]	142	140	138	136	134	131	129	126	123	104	79		
	CVD151/12+C30920T221-V	9,2	12,5	[m]	158	156	154	152	150	148	145	142	139	120	94		
	CVD151/13+C31100T221-V	11	15	[m]	171	169	167	165	162	160	157	154	150	130	102		
	CVD151/14+C31100T221-V	11	15	[m]	184	182	180	177	175	172	169	165	162	140	110		
	CVD151/15+C31100T221-V	11	15	[m]	197	195	193	190	187	184	181	178	174	150	117		
	CVD151/16+C31500T221-V	15	20	[m]	209	206	204	201	198	194	191	187	183	157	123		
	CVD151/17+C31500T221-V	15	20	[m]	222	219	217	214	211	207	203	199	195	167	130		
NPSH				[m]	0,7	0,8	0,9	0,9	1	1	1,1	1,1	1,2	1,8	3,3		

M.E.I. ≥ 0.40

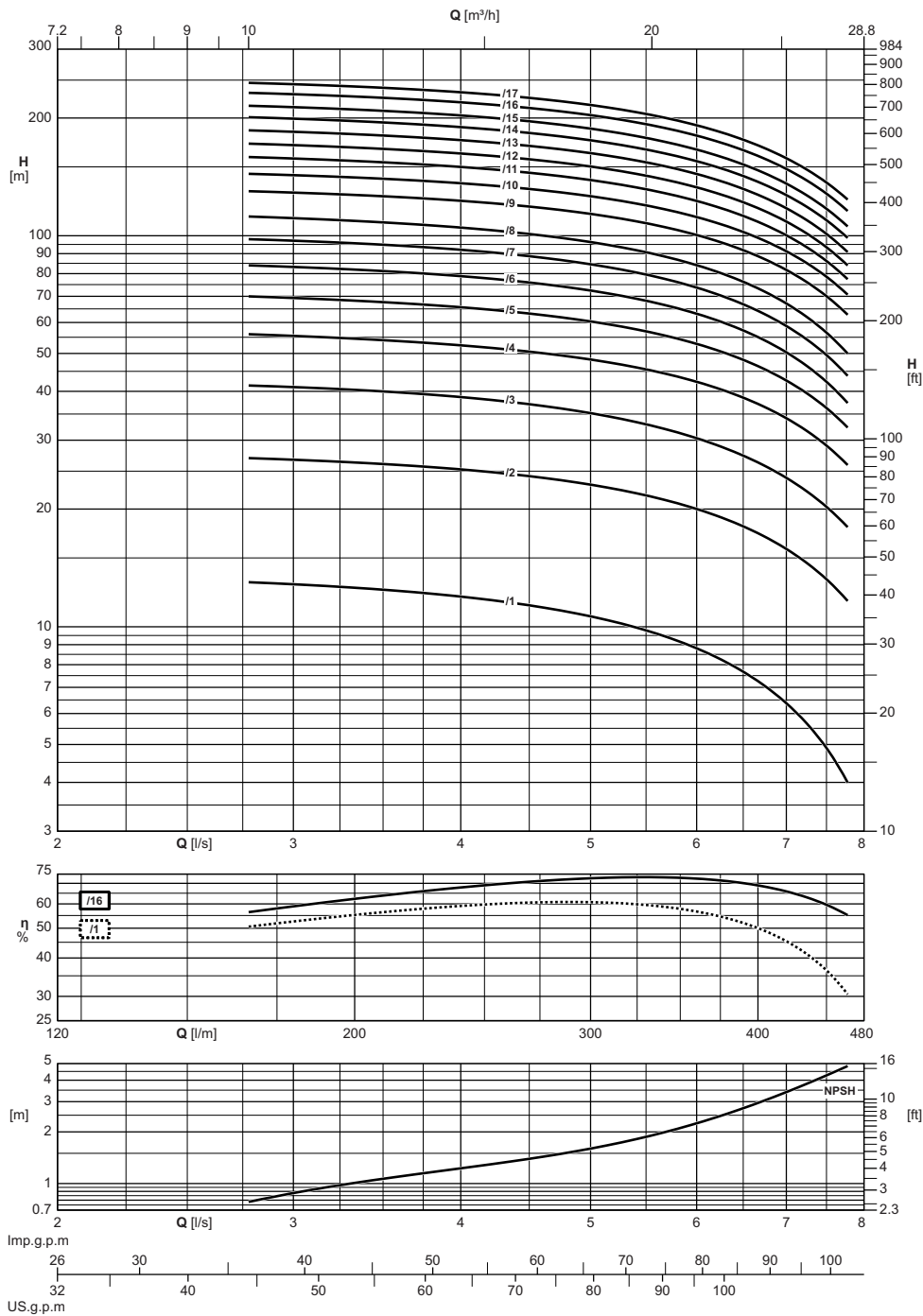

Electric pump type Electropompe type Elettropompa tipo		Motor power Puiss. moteur Potenza motore		Capacity / Debit / Portata														
				[l/s]	2,8	3	3,2	3,4	3,6	3,8	4	5	6	7				
				[m³/h]	10,1	10,8	11,5	12,2	13	13,7	14,4	18	21,5	25				
		[l/min]	168	180	192	204	216	228	240	300	360	420						
Single-phase / Monophasé / Monofase		Three-phase / Triphasé / Trifase		[kW]	[CV]	Total manometric head / Hauteur manometrique totale / Prevalenza manometrica totale												
	CVD201/1+C30110T211-V	1,1	1,5	[m]	13	13	12,5	12,5	12,5	12	12	10,5	8,8	6,4				
	CVD201/2+C30220T211-V	2,2	3	[m]	27	26,5	26,5	26	26	25,5	25,5	23	20	16				
	CVD201/3+C30300T211-V	3	4	[m]	41,5	41	40,5	40	39,5	39	38,5	35	30,5	24				
	CVD201/4+C30400T221-V	4	5,5	[m]	56	55	55	54	54	53	52	48	42,5	34				
	CVD201/5+C30550T221-V	5,5	7,5	[m]	70	69	69	68	67	67	66	60	53	42,5				
	CVD201/6+C30750T221-V	7,5	10	[m]	84	83	82	82	81	80	79	72	63	50				
	CVD201/7+C30750T221-V	7,5	10	[m]	98	97	96	95	94	93	92	85	74	59				
	CVD201/8+C30920T221-V	9,2	12,5	[m]	112	111	110	109	108	106	105	96	84	67				
	CVD201/9+C30920T221-V	9,2	12,5	[m]	130	129	128	127	126	124	123	114	100	82				
	CVD201/10+C31100T221-V	11	15	[m]	144	143	142	141	139	138	136	126	112	91				
	CVD201/11+C31100T221-V	11	15	[m]	159	158	156	155	153	152	150	139	123	100				
	CVD201/12+C31500T221-V	15	20	[m]	172	171	169	168	166	164	162	150	133	109				
	CVD201/13+C31500T221-V	15	20	[m]	186	184	183	181	180	178	176	163	144	118				
	CVD201/14+C31500T221-V	15	20	[m]	201	199	198	196	194	192	190	175	155	127				
	CVD201/15+C31500T221-V	15	20	[m]	215	213	212	210	208	205	203	188	166	136				
	CVD201/16+C31850T221-V	18,5	25	[m]	232	230	228	226	224	222	219	203	180	148				
	CVD201/17+C31850T221-V	18,5	25	[m]	246	244	242	240	238	235	233	216	192	158				
NPSH				[m]	0,8	0,9	1	1	1,1	1,2	1,2	1,6	2,2	3,4				

M.E.I. ≥ 0.40

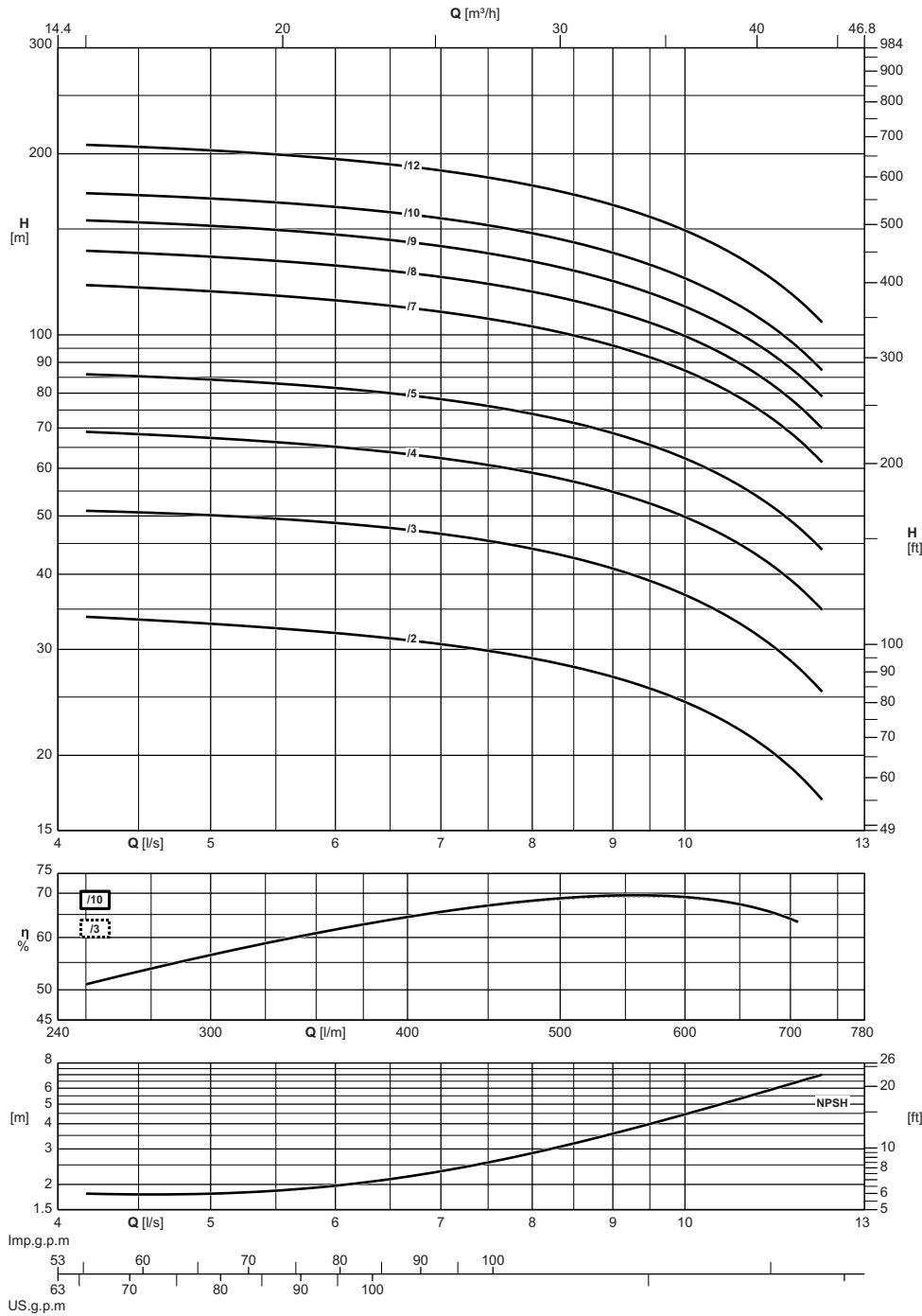

Electric pump type <i>Electropompe type</i> Elettropompa tipo		Motor power <i>Puiss. moteur</i> Potenza motore		Capacity / Debit / Portata												
				[l/s]	5	6	7	8	9	10	11	12				
Single-phase <i>Monophasé</i> Monofase	Three-phase <i>Triphasé</i> Trifase	[kW]	[CV]	[m³/h]	18	21,5	25	29	32	36	40	43				
				[l/min]	300	360	420	480	540	600	660	720				
				Total manometric head <i>Hauteur manométrique totale</i> Prevalenza manometrica totale												
				[m]	33	32	30,5	29	27	24,5	21,5	18				
	CVD321/2+C30400T221-V	4	5,5	[m]	33	32	30,5	29	27	24,5	21,5	18				
	CVD321/3+C30550T221-V	5,5	7,5	[m]	50	48,5	46,5	44	41	37	32,5	27				
	CVD321/4+C30750T221-V	7,5	10	[m]	67	65	62	59	55	50	44	36,5				
	CVD321/5+C31100T221-V	11	15	[m]	84	82	78	74	69	62	55	46				
	CVD321/7+C31500T221-V	15	20	[m]	118	114	109	103	96	87	77	64				
	CVD321/8+C31500T221-V	15	20	[m]	135	130	125	118	110	100	88	73				
	CVD321/9+C31850T221-V	18,5	25	[m]	152	147	140	133	123	111	98	83				
	CVD321/10+C31850T221-V	18,5	25	[m]	169	163	156	148	137	124	109	92				
	CVD321/12+C32200T221-V	22	30	[m]	203	196	188	177	164	149	131	110				
NPSH				[m]	1,8	2	2,3	2,9	3,6	4,5	5,5	6,7				

M.E.I. ≥ 0.40

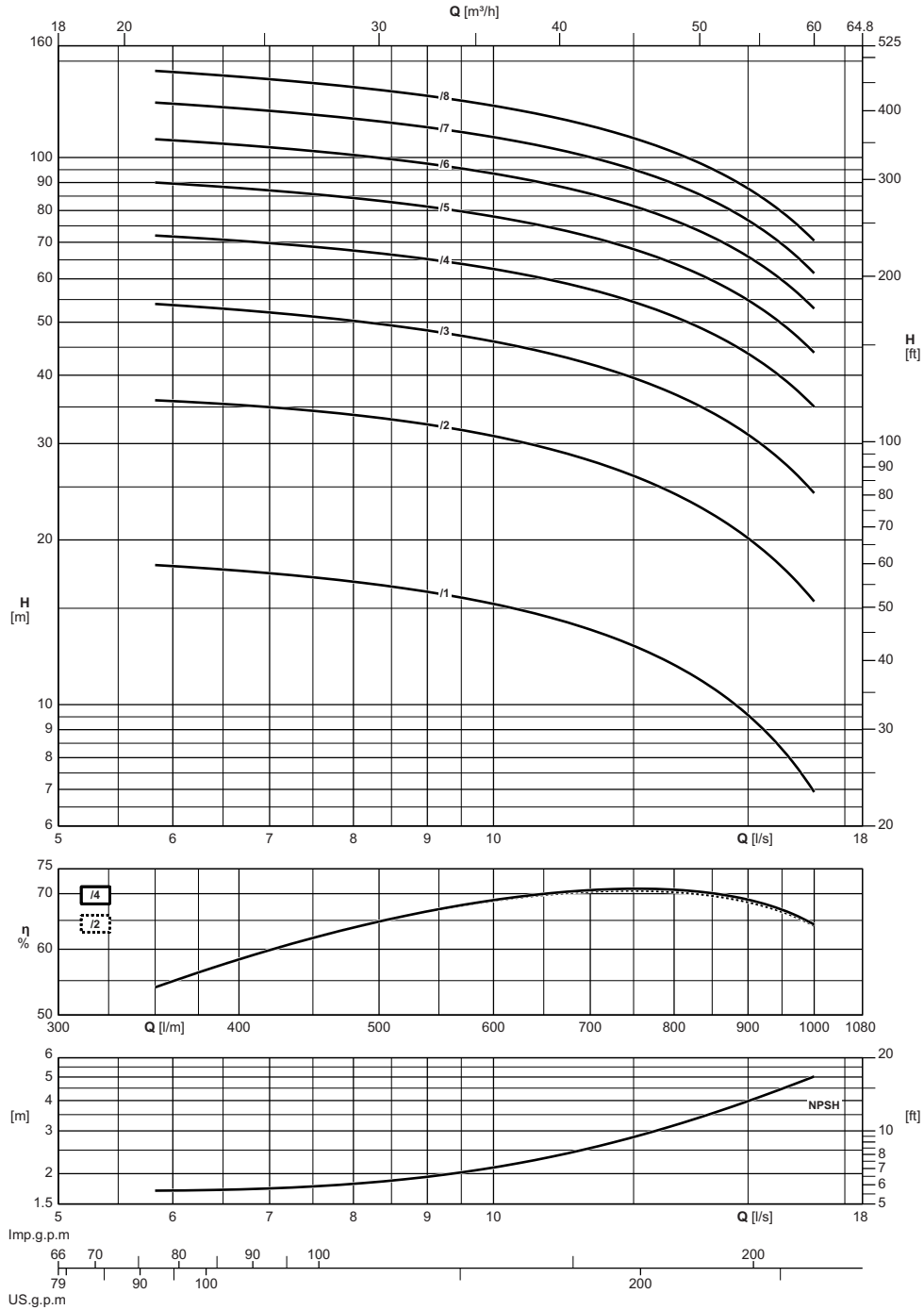

Electric pump type <i>Electropompe type</i> Elettropompa tipo		Motor power <i>Puiss. moteur</i> Potenza motore		Capacity <i>Debit</i> Portata													
				[l/s]	6	7	8	9	10	11	12	13	14	15	16		
				[m³/h]	21,5	25	29	32	36	40	43	47	50	54	58		
				[l/min]	360	420	480	540	600	660	720	780	840	900	960		
Single-phase <i>Monophasé</i> Monofase	Three-phase <i>Triphasé</i> Trifase	[kW]	[CV]	Total manometric head <i>Hauteur manométrique totale</i> Prevalenza manometrica totale													
				[m]	18	17,5	17	16	15,5	14,5	13,5	12	11	9,6	8		
	CVD451/1+C30400T221-V	4	5,5	[m]	36	35	34	32,5	31	29	27	25	22,5	20	17,5		
	CVD451/2+C30550T221-V	5,5	7,5	[m]	54	52	50	48,5	46	43,5	41	38	34,5	31	27		
	CVD451/3+C30750T221-V	7,5	10	[m]	72	70	68	65	63	60	56	53	48,5	44	38,5		
	CVD451/4+C31100T221-V	11	15	[m]	90	87	84	81	78	74	70	66	61	55	48,5		
	CVD451/5+C31500T221-V	15	20	[m]	108	104	101	97	93	89	84	79	73	66	58		
	CVD451/6+C31500T221-V	15	20	[m]	125	122	118	114	109	104	98	92	85	77	68		
	CVD451/7+C31850T221-V	18,5	25	[m]	143	139	135	130	124	119	112	105	97	88	78		
	CVD451/8+C32200T221-V	22	30	[m]	1,7	1,7	1,8	1,9	2,1	2,4	2,7	3	3,5	4	4,6		
NPSH				[m]	1,7	1,7	1,8	1,9	2,1	2,4	2,7	3	3,5	4	4,6		

M.E.I. ≥ 0.40

Overall dimensions and weights
 Dimensions d'encombrement et poids
 Dimensioni di ingombro e pesi

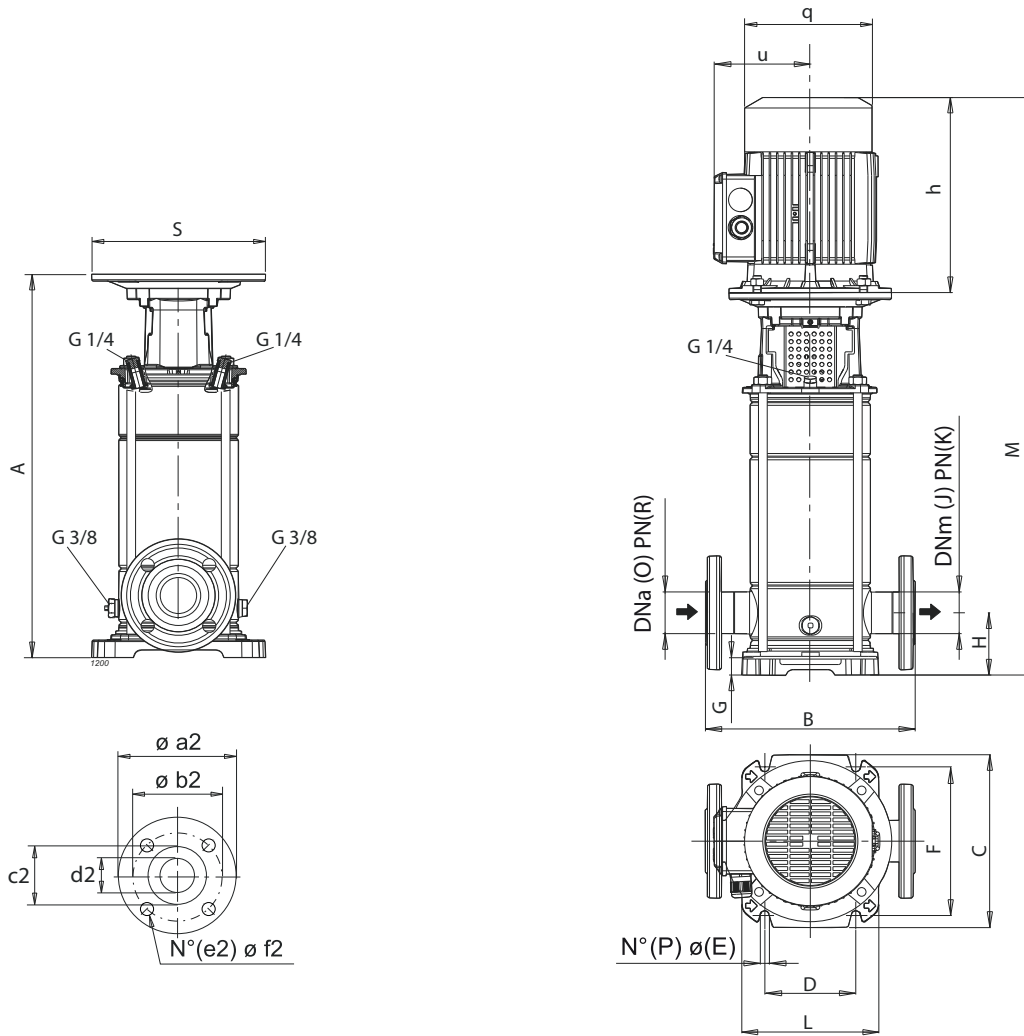

Type Type Tipo	A	B	C	D	E	F	G	H	J	K	L	M	O	P	R	S	h	q	u	a2	b2	c2	d2	e2	f2	Weight Poids Peso
CVD031/4+C30075T211-V	382.5	250	205	100	13	180	35.5	75	25	25-40	165	637.5	25	4	25-40	200	255	157	127.5	115	85	65	25	4	14	31
CVD031/5+C30075T211-V	406.5	250	205	100	13	180	35.5	75	25	25-40	165	661.5	25	4	25-40	200	255	157	127.5	115	85	65	25	4	14	31,9
CVD031/6+C30110T211-V	430.5	250	205	100	13	180	35.5	75	25	25-40	165	685.5	25	4	25-40	200	255	157	127.5	115	85	65	25	4	14	34,5
CVD031/7+C30110T211-V	454.5	250	205	100	13	180	35.5	75	25	25-40	165	709.5	25	4	25-40	200	255	157	127.5	115	85	65	25	4	14	35,3
CVD031/8+C30150T211-V	478.5	250	205	100	13	180	35.5	75	25	25-40	165	733.5	25	4	25-40	200	255	157	127.5	115	85	65	25	4	14	37,4
CVD031/10+C30150T211-V	527	250	205	100	13	180	35.5	75	25	25-40	165	782	25	4	25-40	200	255	157	127.5	115	85	65	25	4	14	38,9
CVD031/12+C30220T211-V	575.5	250	205	100	13	180	35.5	75	25	25-40	165	870.5	25	4	25-40	200	295	157	127.5	115	85	65	25	4	14	43,3
CVD031/14+C30220T211-V	623.5	250	205	100	13	180	35.5	75	25	25-40	165	918.5	25	4	25-40	200	295	157	127.5	115	85	65	25	4	14	45,2
CVD031/16+C30300T211-V	672	250	205	100	13	180	35.5	75	25	25-40	165	988	25	4	25-40	250	316	188	137.5	115	85	65	25	4	14	53,8
CVD031/18+C30300T211-V	720.5	250	205	100	13	180	35.5	75	25	25-40	165	1036.5	25	4	25-40	250	316	188	137.5	115	85	65	25	4	14	55,3
CVD031/20+C30300T211-V	768.5	250	205	100	13	180	35.5	75	25	25-40	165	1084.5	25	4	25-40	250	316	188	137.5	115	85	65	25	4	14	56,8
CVD031/4+C20075M211-V	382.5	250	205	100	13	180	35.5	75	25	25-40	165	637.5	25	4	25-40	200	255	157	127.5	115	85	65	25	4	14	31,5
CVD031/5+C20075M211-V	406.5	250	205	100	13	180	35.5	75	25	25-40	165	661.5	25	4	25-40	200	255	157	127.5	115	85	65	25	4	14	32,6
CVD031/6+C20110M211-V	430.5	250	205	100	13	180	35.5	75	25	25-40	165	685.5	25	4	25-40	200	255	157	127.5	115	85	65	25	4	14	34,5
CVD031/7+C20110M211-V	454.5	250	205	100	13	180	35.5	75	25	25-40	165	709.5	25	4	25-40	200	255	157	127.5	115	85	65	25	4	14	34,9
CVD051/4+C30110T211-V	382.5	250	205	100	13	180	35.5	75	32	25-40	165	637.5	32	4	25-40	200	255	157	127.5	140	100	76	32	4	19	34,1
CVD051/5+C30110T211-V	406.5	250	205	100	13	180	35.5	75	32	25-40	165	661.5	32	4	25-40	200	255	157	127.5	140	100	76	32	4	19	35,2
CVD051/6+C30150T211-V	430.5	250	205	100	13	180	35.5	75	32	25-40	165	685.5	32	4	25-40	200	255	157	127.5	140	100	76	32	4	19	37,3
CVD051/7+C30150T211-V	454.5	250	205	100	13	180	35.5	75	32	25-40	165	709.5	32	4	25-40	200	255	157	127.5	140	100	76	32	4	19	38
CVD051/8+C30220T211-V	478.5	250	205	100	13	180	35.5	75	32	25-40	165	773.5	32	4	25-40	200	295	157	127.5	140	100	76	32	4	19	41,7
CVD051/10+C30220T211-V	527	250	205	100	13	180	35.5	75	32	25-40	165	822	32	4	25-40	200	295	157	127.5	140	100	76	32	4	19	43,2
CVD051/12+C30300T211-V	575.5	250	205	100	13	180	35.5	75	32	25-40	165	886.5	32	4	25-40	250	311	188	137.5	140	100	76	32	4	19	48,2
CVD051/14+C30300T211-V	623.5	250	205	100	13	180	35.5	75	32	25-40	165	934.5	32	4	25-40	250	311	188	137.5	140	100	76	32	4	19	48,3
CVD051/16+C30400T221-V	672	250	205	100	13	180	35.5	75	32	25-40	165	983	32	4	25-40	250	311	188	137.5	140	100	76	32	4	19	58,4
CVD051/18+C30400T221-V	720.5	250	205	100	13	180	35.5	75	32	25-40	165	1031.5	32	4	25-40	250	311	188	137.5	140	100	76	32	4	19	60
CVD051/4+C20110M211-V	382.5	250	205	100	13	180	35.5	75	32	25-40	165	637.5	32	4	25-40	200	255	157	127.5	140	100	76	32	4	19	34,1
CVD051/5+C20110M211-V	406.5	250	205	100	13	180	35.5	75	32	25-40	165	661.5	32	4	25-40	200	255	157	127.5	140	100	76	32	4	19	34,7
CVD101/4+C30150T211-V	411.5	280	250	130	14	215	30.5	80	40	25-40	190	666.5	40	4	25-40	200	255	157	127.5	150	110	84	40	4	19	38

Overall dimensions and weights
 Dimensions d'encombrement et poids
 Dimensioni di ingombro e pesi

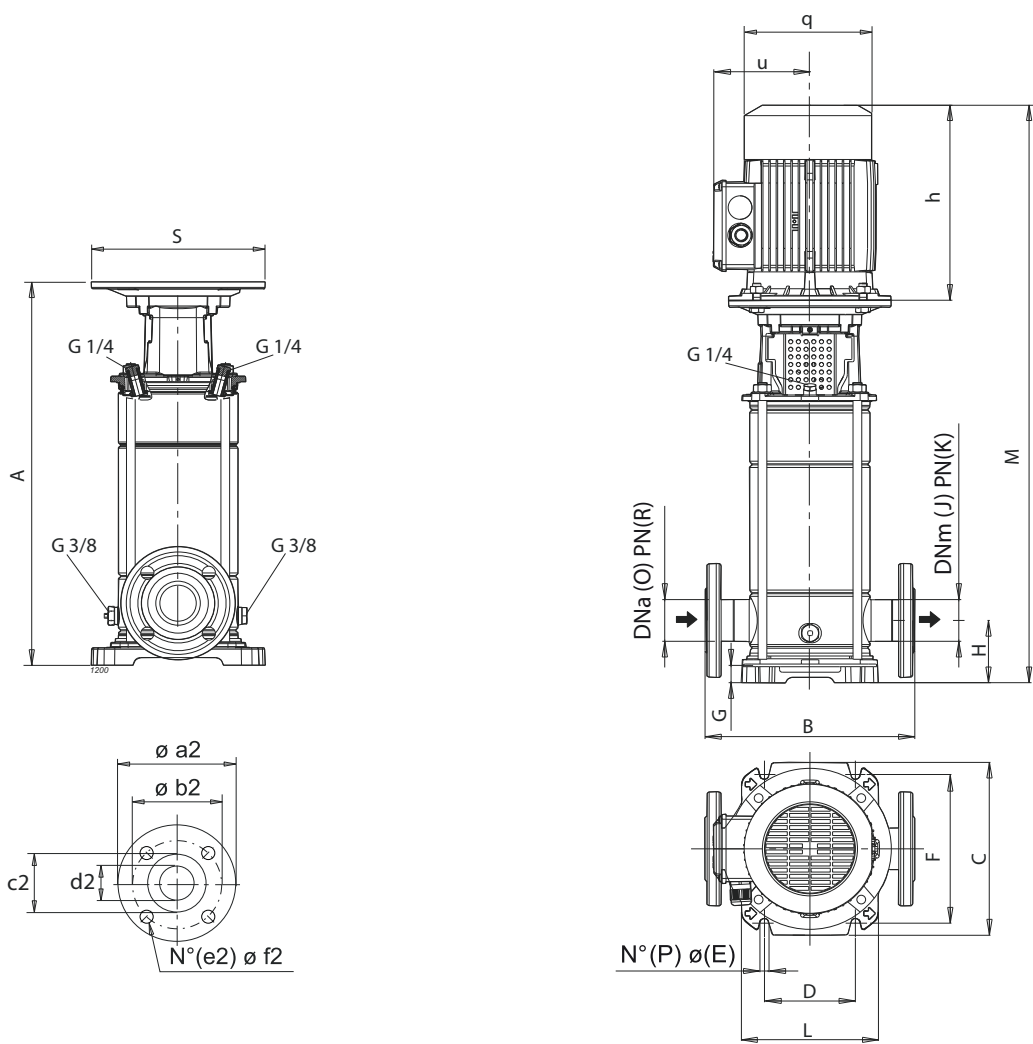

Type Type Tipo	A	B	C	D	E	F	G	H	J	K	L	M	O	P	R	S	h	q	u	a2	b2	c2	d2	e2	f2	Weight Poids Peso
CVD101/5+C30220T211-V	441.5	280	250	130	14	215	30.5	80	40	25-40	190	736.5	40	4	25-40	200	295	157	127.5	150	110	84	40	4	19	42,3
CVD101/6+C30220T211-V	471.5	280	250	130	14	215	30.5	80	40	25-40	190	766.5	40	4	25-40	200	295	157	127.5	150	110	84	40	4	19	43,2
CVD101/7+C30300T211-V	501.5	280	250	130	14	215	30.5	80	40	25-40	190	812.5	40	4	25-40	250	311	188	137.5	150	110	84	40	4	19	52
CVD101/8+C30300T211-V	532	280	250	130	14	215	30.5	80	40	25-40	190	843	40	4	25-40	250	311	188	137.5	150	110	84	40	4	19	52,3
CVD101/10+C30400T221-V	592	280	250	130	14	215	30.5	80	40	25-40	190	903	40	4	25-40	250	311	188	137.5	150	110	84	40	4	19	57,2
CVD101/11+C30400T221-V	62	280	250	130	14	215	30.5	80	40	25-40	190	373	40	4	25-40	250	311	188	137.5	150	110	84	40	4	19	58,6
CVD101/13+C30550T221-V	769.5	280	250	130	14	215	30.5	80	40	25-40	190	1108.5	40	4	25-40	250	339	223	159.5	150	110	84	40	4	19	85,8
CVD101/15+C30550T221-V	830	280	250	130	14	215	30.5	80	40	25-40	190	1169	40	4	25-40	300	339	223	159.5	150	110	84	40	4	19	87,3
CVD101/17+C30750T221-V	890	280	250	130	14	215	30.5	80	40	25-40	190	1229	40	4	25-40	300	339	223	159.5	150	110	84	40	4	19	94,6
CVD101/19+C30750T221-V	950	280	250	130	14	215	30.5	80	40	25-40	190	1289	40	4	25-40	300	339	223	159.5	150	110	84	40	4	19	96,3
CVD151/1+C30110T211-V	438	300	250	130	13	215	25	90	50	25	196	693	50	4	25	200	255	157	127.5	165	125	99	50	4	19	41,5
CVD151/2+C30150T211-V	438	300	250	130	13	215	25	90	50	25	196	733	50	4	25	200	295	157	127.5	165	125	99	50	4	19	44,8
CVD151/3+C30220T211-V	486	300	250	130	13	215	25	90	50	25	196	781	50	4	25	200	295	188	127.5	165	125	99	50	4	19	54,5
CVD151/4+C30300T211-V	534	300	250	130	13	215	25	90	50	25	196	845	50	4	25	250	311	188	137.5	165	125	99	50	4	19	55,8
CVD151/5+C30400T221-V	582	300	250	130	13	215	25	90	50	25	196	893	50	4	25	250	311	188	137.5	165	125	99	50	4	19	61,1
CVD151/6+C30550T221-V	693	300	250	130	13	215	25	90	50	25	196	1032	50	4	25	300	339	223	159.5	165	125	99	50	4	19	86,5
CVD151/7+C30550T221-V	741	300	250	130	13	215	25	90	50	25	196	1080	50	4	25	300	339	223	159.5	165	125	99	50	4	19	88,4
CVD151/8+C30550T221-V	789	300	250	130	13	215	25	90	50	25	196	1128	50	4	25	300	339	223	159.5	165	125	99	50	4	19	89,3
CVD151/9+C30750T221-V	837	300	250	130	13	215	25	90	50	25	196	1176	50	4	25	300	339	223	159.5	165	125	99	50	4	19	96,5
CVD151/10+C30750T221-V	885	300	250	130	13	215	25	90	50	25	196	1224	50	4	25	300	339	223	159.5	165	125	99	50	4	19	99
CVD151/11+C30920T221-V	963	300	250	130	13	215	25	90	50	25	196	1376	50	4	25	350	413	263.4	186	165	125	99	50	4	19	128
CVD151/12+C30920T221-V	1011	300	250	130	13	215	25	90	50	25	196	1424	50	4	25	350	413	263.4	186	165	125	99	50	4	19	129,3
CVD151/13+C31100T221-V	1059	300	250	130	13	215	25	90	50	25	196	1518	50	4	25	350	459	263.4	186	165	125	99	50	4	19	136,7
CVD151/14+C31100T221-V	1107	300	250	130	13	215	25	90	50	25	196	1566	50	4	25	350	459	263.4	186	165	125	99	50	4	19	138,2
CVD151/15+C31100T221-V	1155	300	250	130	13	215	25	90	50	25	196	1614	50	4	25	350	459	263.4	186	165	125	99	50	4	19	139,7
CVD151/16+C31500T221-V	1203	300	250	130	13	215	25	90	50	25	196	1687	50	4	25	350	484	263.4	186	165	125	99	50	4	19	165
CVD151/17+C31500T221-V	1251	300	250	130	13	215	25	90	50	25	196	1735	50	4	25	350	484	263.4	186	165	125	99	50	4	19	167,7
CVD201/1+C30110T211-V	438	300	250	130	13	215	25	90	50	25	196	693	50	4	25	200	255	157	127.5	165	125	99	50	4	19	42,3
CVD201/2+C30220T211-V	438	300	250	130	13	215	25	90	50	25	196	733	50	4	25	200	295	157	127.5	165	125	99	50	4	19	46,3

Overall dimensions and weights
 Dimensions d'encombrement et poids
 Dimensioni di ingombro e pesi

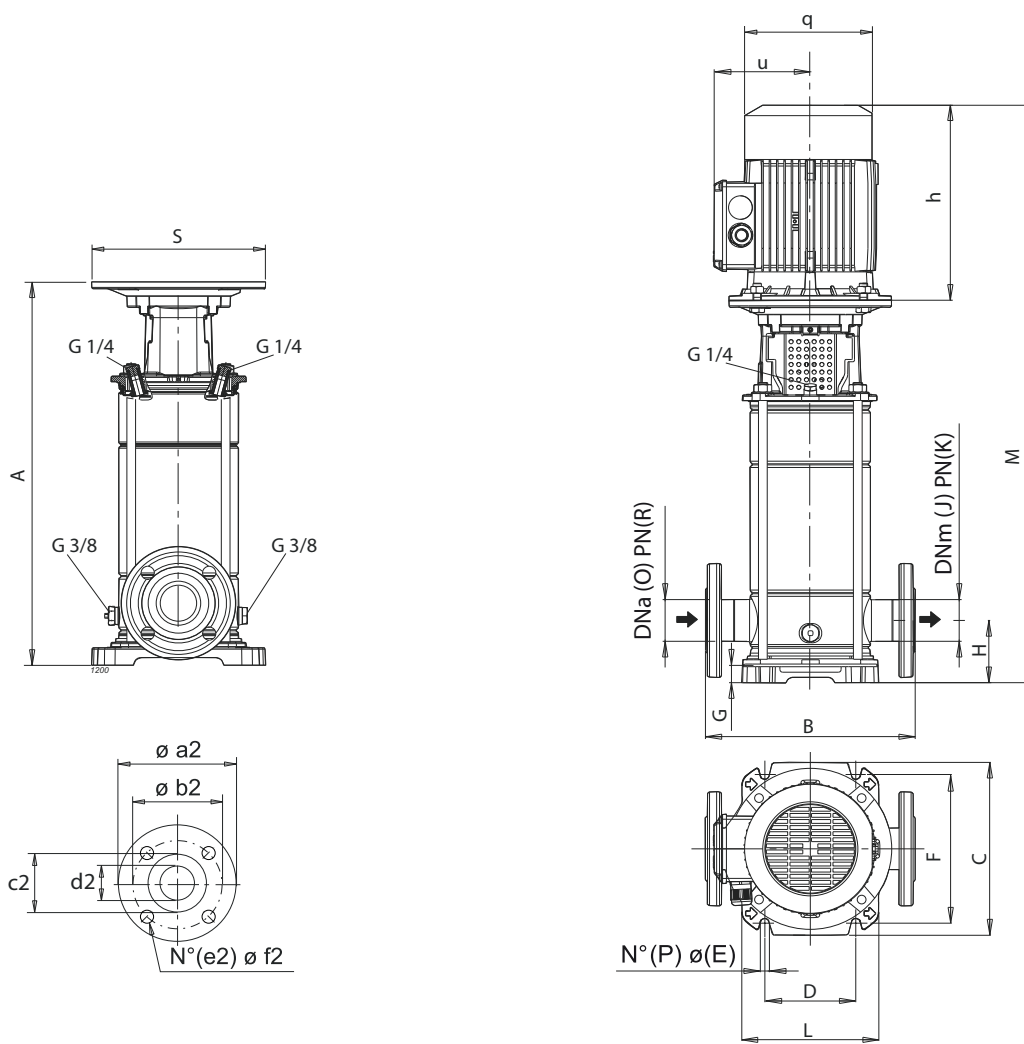

Type Type Tipo	A	B	C	D	E	F	G	H	J	K	L	M	O	P	R	S	h	q	u	a2	b2	c2	d2	e2	f2	Weight Poids Peso
CVD201/3+C30300T211-V	486	300	250	130	13	215	25	90	50	25	196	797	50	4	25	250	311	188	137.5	165	125	99	50	4	19	53,2
CVD201/4+C30400T221-V	521	300	250	130	13	215	25	90	50	25	196	832	50	4	25	250	311	188	137.5	165	125	99	50	4	19	56,8
CVD201/5+C30550T221-V	645	300	250	130	13	215	25	90	50	25	196	984	50	4	25	300	339	223	159.5	165	125	99	50	4	19	84,6
CVD201/6+C30750T221-V	693	300	250	130	13	215	25	90	50	25	196	1032	50	4	25	300	339	223	159.5	165	125	99	50	4	19	89,2
CVD201/7+C30750T221-V	741	300	250	130	13	215	25	90	50	25	196	1080	50	4	25	300	339	223	159.5	165	125	99	50	4	19	90,6
CVD201/8+C30920T221-V	819	300	250	130	13	215	25	90	50	25	196	1232	50	4	25	350	413	263.4	186	165	125	99	50	4	19	120,7
CVD201/9+C30920T221-V	867	300	250	130	13	215	25	90	50	25	196	1280	50	4	25	350	413	263.4	186	165	125	99	50	4	19	122,1
CVD201/10+C31100T221-V	915	300	250	130	13	215	25	90	50	25	196	1374	50	4	25	350	459	263.4	186	165	125	99	50	4	19	129,6
CVD201/11+C31100T221-V	963	300	250	130	13	215	25	90	50	25	196	1422	50	4	25	350	459	263.4	186	165	125	99	50	4	19	133,8
CVD201/12+C31500T221-V	1011	300	250	130	13	215	25	90	50	25	196	1495	50	4	25	350	484	263.4	186	165	125	99	50	4	19	161,3
CVD201/13+C31500T221-V	1059	300	250	130	13	215	25	90	50	25	196	1543	50	4	25	350	484	263.4	186	165	125	99	50	4	19	164,1
CVD201/14+C31500T221-V	1107	300	250	130	13	215	25	90	50	25	196	1591	50	4	25	350	484	263.4	186	165	125	99	50	4	19	164,2
CVD201/15+C31500T221-V	1155	300	250	130	13	215	25	90	50	25	196	1639	50	4	25	350	484	263.4	186	165	125	99	50	4	19	167
CVD201/16+C31850T221-V	1203	300	250	130	13	215	25	90	50	25	196	1687	50	4	25	350	484	315	186	165	125	99	50	4	19	192
CVD201/17+C31850T221-V	1251	300	250	130	13	215	25	90	50	25	196	1735	50	4	25	350	484	315	186	165	125	99	50	4	19	192,2

Overall dimensions and weights
 Dimensions d'encombrement et poids
 Dimensioni di ingombro e pesi

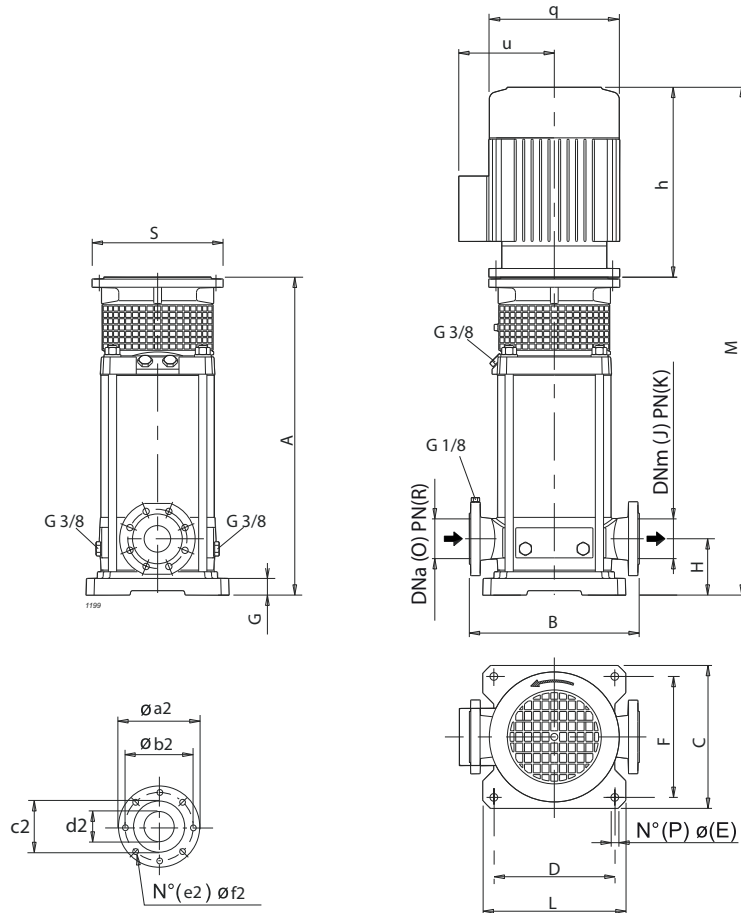

Type Type Tipo	A	B	C	D	E	F	G	H	J	K	L	M	O	P	R	S	h	q	u	a2	b2	c2	d2	e2	f2	Weight Poids Peso
CVD321/2+C30400T221-V	407	320	260	220	14	220	35	105	65	25-40	260	718	65	4	25-40	250	311	188	137.5	185	145	118	65	8	19	72
CVD321/3+C30550T221-V	473	320	260	220	14	220	35	105	65	25-40	260	812	65	4	25-40	300	339	223	159.5	185	145	118	65	8	19	93
CVD321/4+C30750T221-V	519	320	260	220	14	220	35	105	65	25-40	260	858	65	4	25-40	300	339	223	159.5	185	145	118	65	8	19	100,7
CVD321/5+C31100T221-V	595	320	260	220	14	220	35	105	65	25-40	260	1054	65	4	25-40	350	459	263.4	186	185	145	118	65	8	19	138
CVD321/7+C31500T221-V	687	320	260	220	14	220	35	105	65	25-40	260	1171	65	4	25-40	350	484	263.4	186	185	145	118	65	8	19	168
CVD321/8+C31500T221-V	733	320	260	220	14	220	35	105	65	25-40	260	1217	65	4	25-40	350	484	263.4	186	185	145	118	65	8	19	170
CVD321/9+C31850T221-V	779	320	260	220	14	220	35	105	65	25-40	260	1290	65	4	25-40	350	538	315	206	185	145	118	65	8	19	192,7
CVD321/10+C31850T221-V	825	320	260	220	14	220	35	105	65	25-40	260	1363	65	4	25-40	350	538	315	206	185	145	118	65	8	19	194,7
CVD321/12+C32200T221-V	917	320	260	220	14	220	35	105	65	25-40	260	1455	65	4	25-40	350	538	315	206	185	145	118	65	8	19	204,8
CVD451/1+C30400T221-V	411	320	260	220	14	220	35	105	80	25-40	260	722	80	4	25-40	250	311	188	137.5	200	160	132	80	8	19	73,3
CVD451/2+C30550T221-V	466	320	260	220	14	220	35	105	80	25-40	260	805	80	4	25-40	300	339	223	159.5	200	160	132	80	8	19	93,8
CVD451/3+C30750T221-V	527	320	260	220	14	220	35	105	80	25-40	260	866	80	4	25-40	300	339	223	159.5	200	160	132	80	8	19	103,2
CVD451/4+C31100T221-V	618	320	260	220	14	220	35	105	80	25-40	260	1077	80	4	25-40	350	459	263.4	186	200	160	132	80	8	19	154
CVD451/5+C31500T221-V	680	320	260	220	14	220	35	105	80	25-40	260	1164	80	4	25-40	350	484	263.4	186	200	160	132	80	8	19	165,5
CVD451/6+C31500T221-V	741	320	260	220	14	220	35	105	80	25-40	260	1225	80	4	25-40	350	484	263.4	186	200	160	132	80	8	19	171
CVD451/7+C31850T221-V	802	320	260	220	14	220	35	105	80	25-40	260	1340	80	4	25-40	350	538	315	206	200	160	132	80	8	19	195
CVD451/8+C32200T221-V	864	320	260	220	14	220	35	105	80	25-40	260	1402	80	4	25-40	350	538	315	206	200	160	132	80	8	19	203,8

MEI = 0.4 for Multistage Vertical 2900rpm

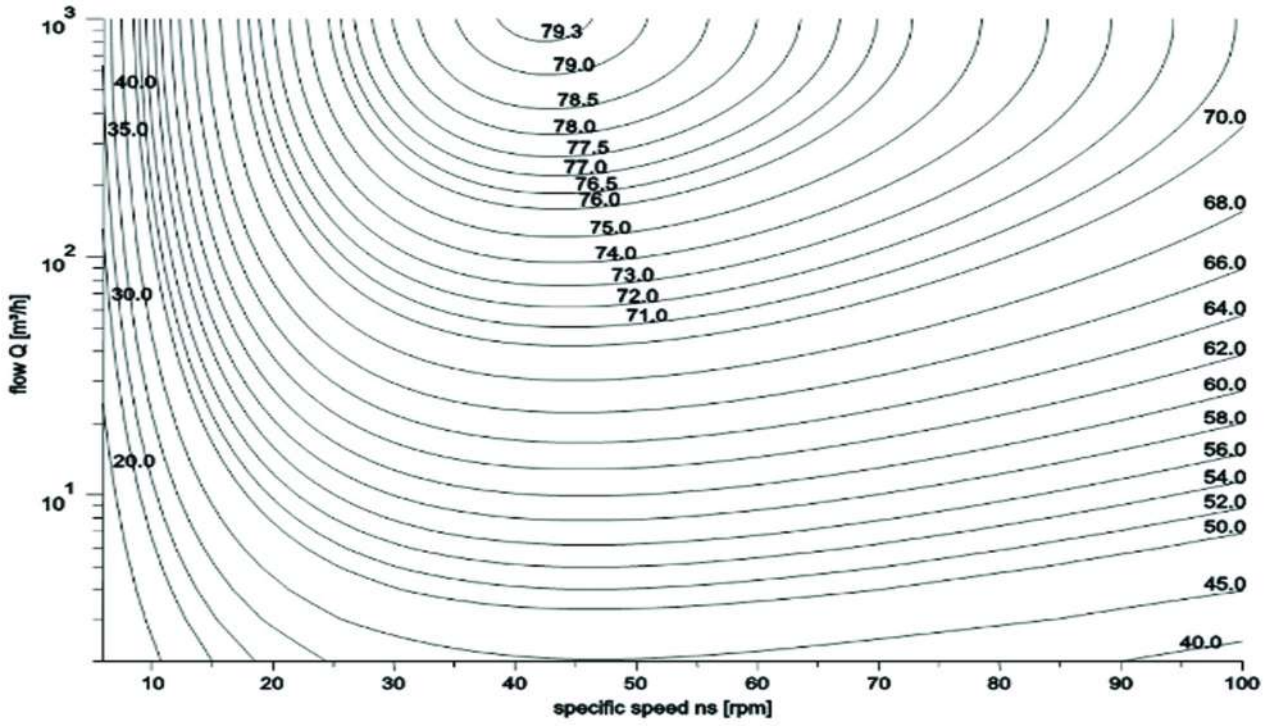

MEI=0.7 for Mutistage Vertical 2900 rpm

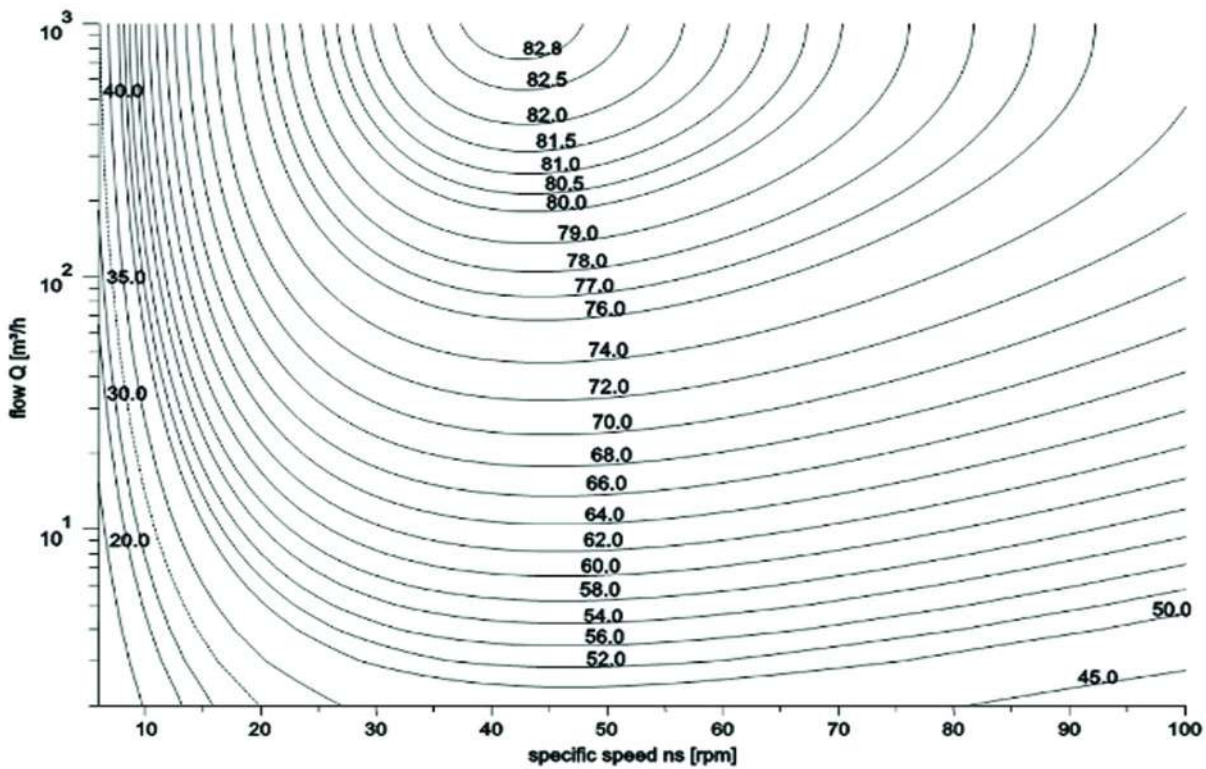

caprari

The dimensions have an indicative value. Executive drawing will be supplied on request upon order.
CAPRARI S.p.A. reserves the right to make changes to improve its products at any time and without any notice

*Les dimensions sont fournies à titre indicatif. Le plan bon pour exécution sera fourni sur demande au moment de la commande.
CAPRARI S.p.A. se réserve la faculté d'apporter des modifications visant à améliorer ses propres produits à tout moment et sans aucun préavis.*

**Le dimensioni hanno valore indicativo. Il disegno esecutivo sarà fornito su richiesta in fase d'ordine.
CAPRARI S.p.A. si riserva facoltà di apportare modifiche atte a migliorare i propri prodotti in qualsiasi momento e senza preavviso alcuno.**